

# **COBRA**

**Class 8810**

**Industrial Sewing Machine**

**Instruction & Parts Manual**

---



# 8810/8820型羅拉車使用說明書

8810/8820 POST-BED COMPOUND FEED WITH KOUER LOCKSTITCH SEWING MACHINE INSTRUCTION BOOK

感謝您選購8810/8820型高頭縫紉機。

這是使用說明和零件目錄的綜合本，旨在幫助您正確掌握機器的調整、保養及方便查詢零件規格。

為避免故障產生，請在使用機器前認真閱讀使用說明手冊；并接受有操作經驗者或專業維修技術人員的安全操作指導。

Thank you to choose 8810/8820 Post-bed compound feed clockstitch sewing machine with roller.

This is a instruction book & parts list.it could help you how to use machine & how to care of machine correctly and make you convenience to look up parts. In order to avoid trouble occurring,please read this instruction book carefully before operating machine,and please accept safety operating guides which come from special technicians or peoples of having operator experiences.

## 1、機器簡介

8810(單針)/8820(雙針)高頭縫紉機屬高頭車系列中的高檔產品。外形美觀新穎；縫目精確一致、大小自由調節；採用球型及針狀軸承，運轉輕滑；採用輪式狗齒與驅動式輪錢，爬坡車縫性能極佳；特別適用於高檔皮鞋、箱包、手套等弧形皮革制品。

### 1、BRIEF INTRODUCTION OF MACHINE

8810 ( Single needle ) /8820 ( Double needle ) Post-bed compound feed with roller clockstitch sewing machine is a high-grade product of Post-bed sewing machine .it's surface beautiful and it's stitch could be adjusted freely . before you adjusting it , the stitch could keep not changing. maintenance-free ball &needle bearing, it works smoothly. owing to the combination of wheel feed and driven rollerpresser . it's climbing capacity is very good .it is special suitable for sewing high-grade leather shoes,bags & gloves etc. arc leather products.

## 2、主要技術規格

- 1、最高縫紉機速度：2500針/分；
- 2、針距調節範圍：1.3~7mm；
- 3、壓腳提升高度：（手支、膝控）7mm；
- 4、針杆行程：41mm；
- 5、採用機針：DPx5、11#~20#；

6、使用旋梭：立式旋梭；

7、縫厚能力：6mm；

8、潤滑方式：手工注油；

9、電動機：370W（離合式縫紉機專用電機）

## 2、MAIN SPECIFICATIONS

1、Max . Sewing Speed:2500 needle/min.

2、Scope of Needle Stitch Adjusted:1.3~7mm.

3、Presser Foot Lift:7mm.

4、Needle Travel:41mm.

5、Need System:DPx5、11#~20#.

6、Hook Assy. Type: Vertical Hook Assy.

7、Sewing Capacity:6mm.

8、Lubrication Way : Lubricating By Hand.

9、Motor:370W(Clutch Motor Special Used For Sewing Machine)

## 3、注意

a、機器裝箱出廠前，雖已經過周密檢驗，但在長途運轉中、也可能受到強烈的振動使機件鬆動或歪曲，所以機器在安裝使用前應作仔細的檢查，在確定沒有轉運困難、碰撞或不均勻的阻力、不正常的響聲等才可正式試車。

b、機器的旋梭、送料滾輪、夾綫調節器等零件的過綫處容易積累灰塵、污物，影響縫紉性能，因此這些部位要經常清潔打掃。

c、在清潔機器後，請使用優質縫紉機油對機器進行一次各方法的注油潤滑。

d、在縫料、縫綫有較大變動，更換易損件等影響機器間隙需作調整時，建議請有操作經驗者或專業維修技術人員進行。

### 3、BE CAREFUL

a、Before the machine leaving factory,it had already been checked carefully,but in long-distance transport, it may be vibrated strongly and then parts loosen or wound,so before installing & using the machine,you must check it carefully,when you ascertained that there is no trouble for rotating,no colliding,no unregular resistance and on unnormal sound ,you could trying it.

b. Hook assy, feed wheel & thread tension regulator assy etc. Parts of the machine is easily accumulated dust, and this would affect sewing capacity. So you must often clean it.

c. After you cleaned the machine, please oil all the position which need iubricating use sewing-machine oil.

d. If sewing material and thread was changed or the vulnerable parts was replaced, the clearance of machine may be needed adjusting, in this time, you had better to adjust it through special technicians or peoples of having operator experience.

#### 4. 安裝機針 (圖1)

請使用DPX5、11# ~ 20# 機針，機針的精細應根據縫料的性質，及綫的粗細來選擇。

將機針的長槽A朝向操作者的左面，把針柄插入針孔內，一定要接觸到針杆孔的底部，再旋緊夾針螺釘，固定機針。

#### 4. INSTALLATION OF NEEDLE ( Drawing 1 )

Please use DPX5、11# ~ 20# needle, the thickness of needle should be decided according to the thickness of sewing material & thread.

When you installing needle, the needle's long slot should face the operator's left side, then put the needle shank into needle hole, and take it up to the bottom of needle hole, then tighten the clamping screw.

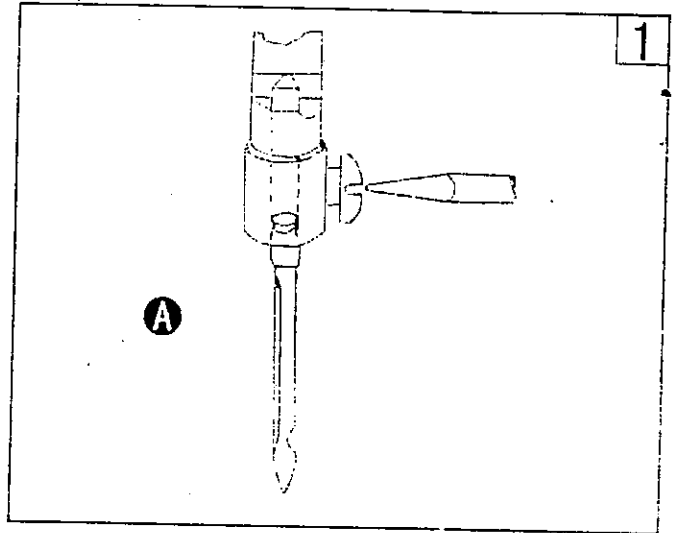

#### 5. 梭心綫的繞取方法 (圖2)

將梭芯(B)插入繞綫軸中，自綫團來的綫(A)先夾入二夾綫盤(E)的中間，然後把綫頭在梭芯(B)上繞幾圈，把繞綫擺杆(D)向上扳起，使擺杆彈簧板(C)壓向梭芯(B)。運轉縫紉時就能自動繞綫（不縫紉、祇繞綫時一定要抬起壓腳）。

梭芯綫繞好後，可通過切綫刀片來切斷梭心綫，把綫(A)在切綫刀片(B)上繞二圈，然後用力一拉就完成切綫動作。

#### 5. HOW TO WIND THE BOBBIN (Drawing 2)

Put the bobbin (B) on the winder spindle, and clamp thread (A) from spool between two tension discs (E), then wind the thread on bobbin several times, take up the oscillating shaft (D), then spring plate of oscillating shaft (C) press the bobbin (B). When sewing it auto winding. (if not sewing, and only need to wind, please raise up presser feet.)

After winded the bobbin, you may cut bobbin thread use cutting-thread blade (B), wind thread (A) on cutting-thread knife (B) two times, then pull it use your strength, the thread is cut.

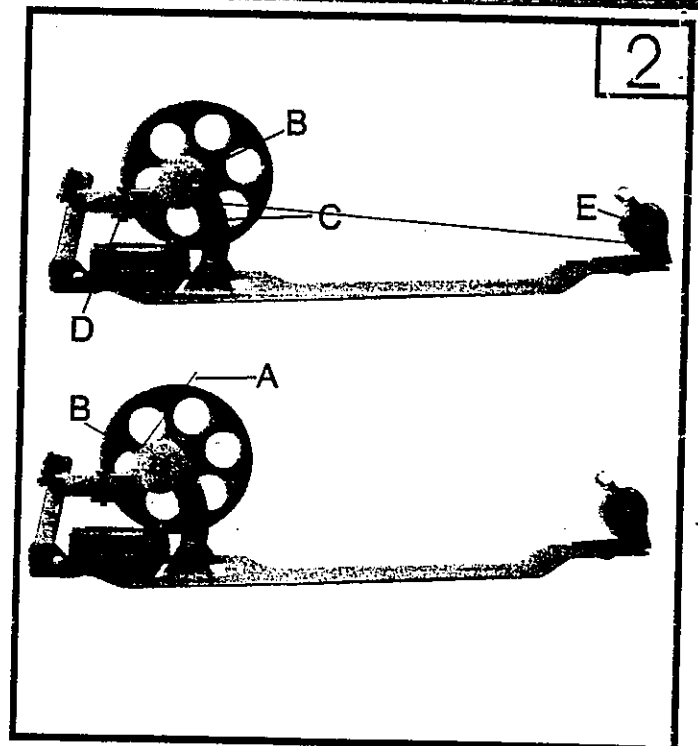

6. 將梭心放入梭殼的方法 (圖3)

- a. 打開旋梭防護蓋 (A)。
- b. 扳起梭門扳手 (B)。
- c. 將梭心線拉出50mm左右，將線頭嵌入梭心套開口槽內。
- d. 將放入梭心的梭心套放入旋梭內。
- e. 關上梭門扳手 (B)。
- f. 左手拿機針線，右手轉運主動輪將勾上的梭心線放置一邊。
- g. 關上旋梭防護蓋 (A)。

**6. THE METHOD OF PUTTING BOBBIN & BOBBIN CASE IN HOOK ASSY. (Drawing3)**

- a. Open post cap assy(A).
- b. Lift up bobbin lever(B).
- c. Lead bobbin thread out about 50mm, then put the end of thread in slot of bobbin case.
- d. Put the bobbin case with bobbin in hook assy.
- e. Put down bobbin lever(B).
- f. Leading needle thread by left hand, rotating driving wheel by right hand, when the bobbin thread is pulled out, then put the bobbin thread on a side.
- g. Closed the post cap assy(A).

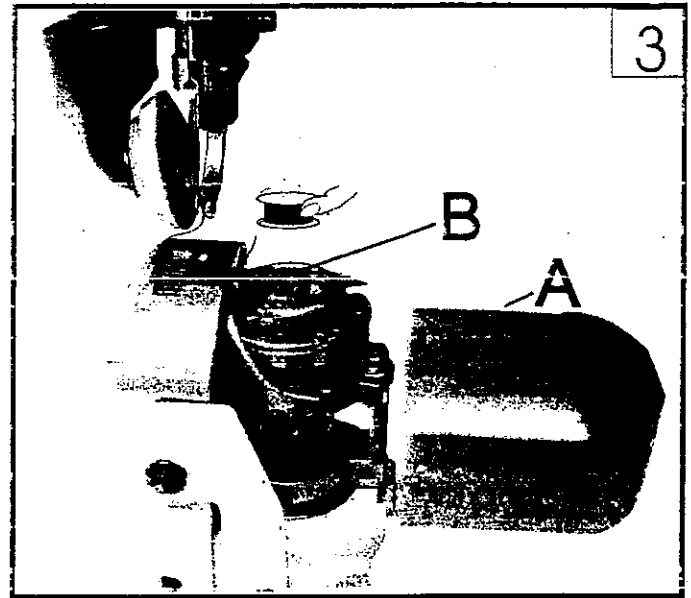

7. 穿線的方法 (圖4)

穿線時針杆應在最高位置，提起壓腳，打開滾輪壓腳（向下施力并按圖箭頭方向扳動），然後將線架上引出線按順序穿線。

- a. 穿過上面過線釘上二孔。
- b. 從右到左穿過來線調節安裝板右過線孔；然後向上把線夾入小夾線板②之間。
- c. 向下繞過分線梢，在夾線板③之間通過。
- d. 從右向左繞過線控板組件④。
- e. 向上穿過上過線勾⑤，從右向左穿過挑線杆穿線孔。
- f. 向下穿過中過線勾⑥，下過線勾⑦及針杆線孔⑧，從左面穿過機針⑨的針孔，並引出100mm左右的線備用。

**7. THE WAY OF THREADING. (Drawing4)**

When threading the needle thread, the needle bar should be on the position of highest point. lift up presser feet, open the roller presser assy(pull it down, then push it along with the direction of arrow). then lead the end of thread from spool & threading in order

- a. Leading thread through two holes of 4 hole thread retainer(1)
- b. Leading thread from right to left through the right threading hole of tensioning adjusting-plate, then leading it up and clamping it between small tension discs(2).
- c. Go round dividing thread pin downward, pass through tension discs(3).
- d. Go round thread tension plate assy(4) from right to left.
- e. Leading thread up and pass through upper thread guide(5), then pass through the hole of thread take up lever from right to left.
- f. Downward through middle thread guide(6), under thread guide(7) & needle bar's hole(8), pass through the hole of needle(9), and leading thread out about 100mm for using.

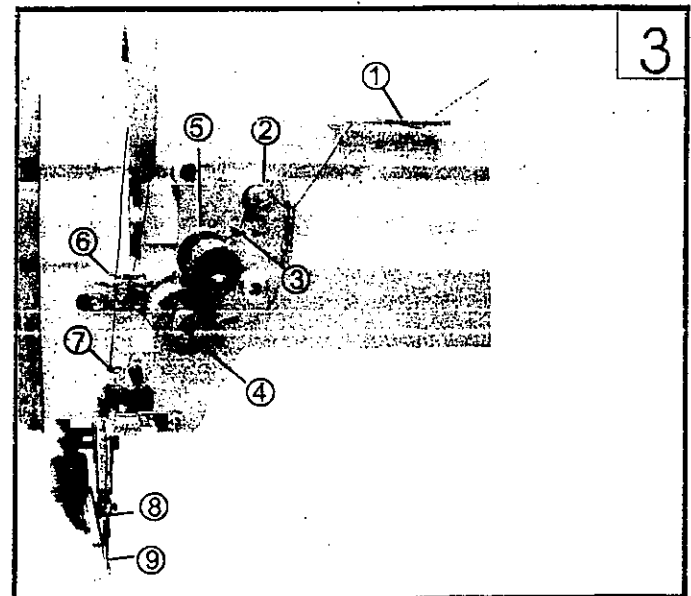

縫紉機的正常針線應如圖A，如果縫迹不正常，會出現縫料起皺、斷線現象，應暫底，而線的張力加以調節，使之達到正常的縫迹

- a、如果縫迹如圖B所示，說明針線過緊或梭芯線張力太鬆，則應逆時針旋轉夾線螺母，以放緩面線的壓力，或用小號螺絲起子旋緊調校螺絲（B），加大底線的張力
- b、如果針線太鬆，底線太緊，如圖C所示，則應順時針旋轉夾線螺母，以加大面線壓力；或用小號螺絲起子旋鬆調校螺絲（B），減小底線的張力。

**8、ADJUSTING OF THREAD TENSION (Drawing5、6、7)**

The normal stitch of this sewing machine should be as same as drawing A showing. If the stitch is unnormal, it may appear thread breaking or sewing material wrinkling etc. In this time, you should adjust the tension of needle thread & bobbin thread until the stitch is good.

a. If the stitch is as same as drawing B showing, it means that the tension of needle thread is too high or the tension of bobbin thread is too low. You should turn tension nut clockwise so that reduce the pressure of needle thread. Or tighten the adjusting-screw(B) using small screwdriver to increase the tension of bobbin thread.(seeing drawing15、16).

b. Showing as drawing C, If the tension of needle thread is too small & the tension of bobbin thread is too big, you should turn tension nut clockwise to increase the pressure of needle thread. or loosen the adjusting-screw(B) using small screwdriver to reduce the tension of bobbin thread.

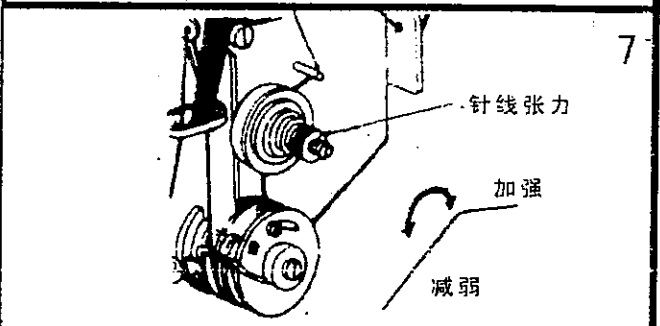
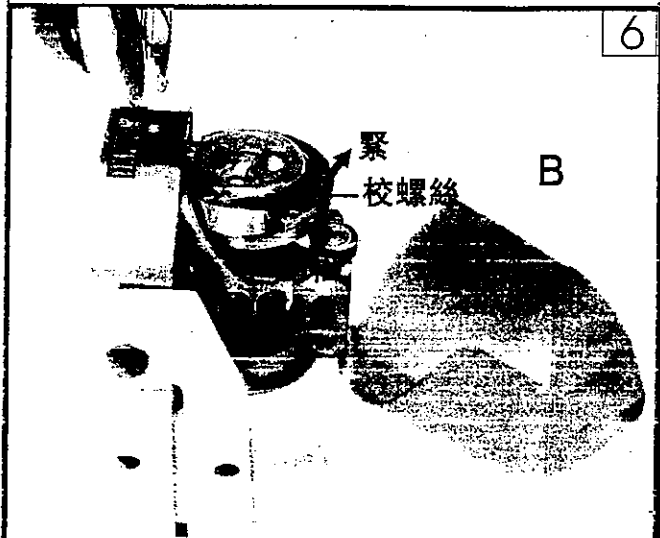
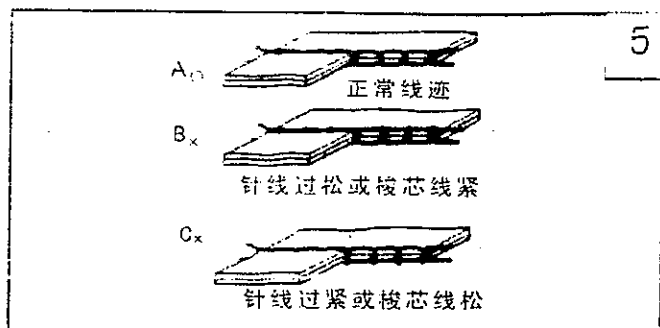

**9、滾輪壓力調節 (圖8)**

滾輪壓腳的壓力要根據縫料厚度加以調節，如縫厚料，應加大壓腳壓力，這時將機頭背部調校螺絲按圖順時針方向旋入即可；反之，就減小壓腳壓力。

**9、REGULATING THE PRESSURE OF PRESSER FEET (Drawing8)**

The pressure of presser feet should be regulated according to the thickness of sewing material. If the sewing material is more thicker, the pressure of presser feet should be increased, in this time, you may turn round regulating-screw on the back of head clockwise as drawing showing. on contrary, reduce the pressure.

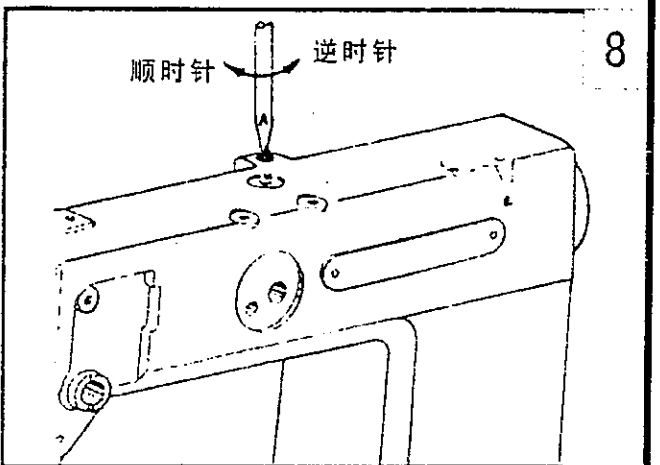

- a. 用左手食指用力微壓針距調節按鈕 (B)。
- b. 右手慢慢轉動上輪 (A)。
- c. 當針距調節按鈕按下後，即可調節針距大小。
- d. 針距的大小，在上輪上已標出，數值越大，針距越大，繼續轉動上輪，當你想選針距數值對準基準點 (C) 時放開針距調節按鈕 (B)，此時 (B) 恢復到原位，所需針距也就調好。

**10、REGULATING STITCH LENGTH (Drawing9)**

- a. Press down the stitch length regulating-button(B) using forefinger of left hand.
- b. Turn round the pulley blance wheel(A) slowly by right hand.
- c. When the stitch length regulating-button (B) was pressed down, you may regulate the stitch length.
- d. The figure of stitch length is shown on the pulley blance wheel (A), the figure is more bigger then the stitch length is more bigger, turning round the pulley blance wheel(A) until the figure of stitch length you need aim at datum poing (C), then loosen the stitch Length regulating-button(B) and it return back to the original position. Then the stitch length is regulated good.

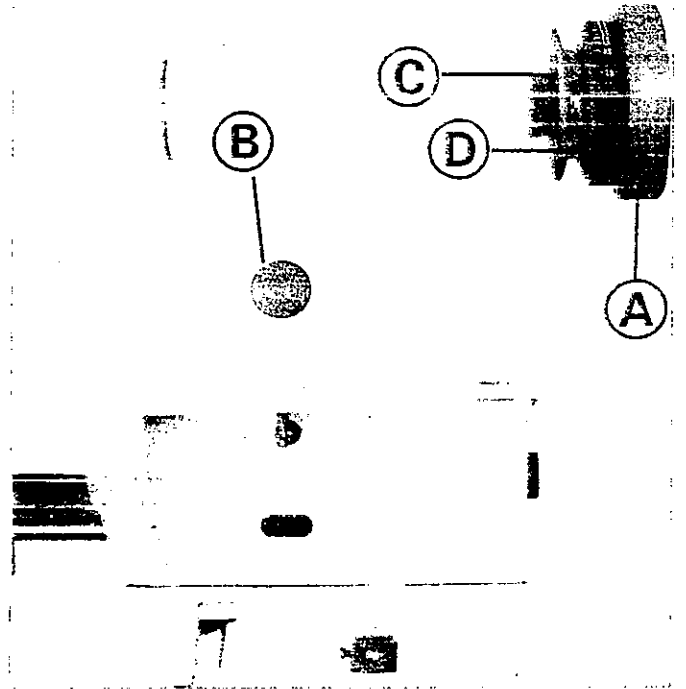

**11. 旋梭與機針間隙調節 (圖10)**

旋梭與機針間隙調節建議請有操作經驗者及專業維修技術人員進行

- a. 用手轉動上輪，當機針在最低位置上升2mm時，針孔低於梭尖1.6mm。
- B. 用手轉動上輪，當機針在最低位置上升2mm時，梭尖正對針凹槽，間隙為0.05mm。

**11、REGULATING THE GAP BETWEEN HOOK ASSY AND NEEDLE (Drawing10)**

We suggest that the gap between hook assy and needle should be regulated by special technicians or peoples having operating experiences.

- a. Turning round the pulley blance wheel by hand, when The needle go up 2mm from the lowest position, the position of needle hole should be lower 1.6mm than hook top.
- b. Turning round the pulley blance wheel by hand, when the needle go up 2mm from the lowest position, hook gap should aim at needle slot and the gap is 0.05mm.

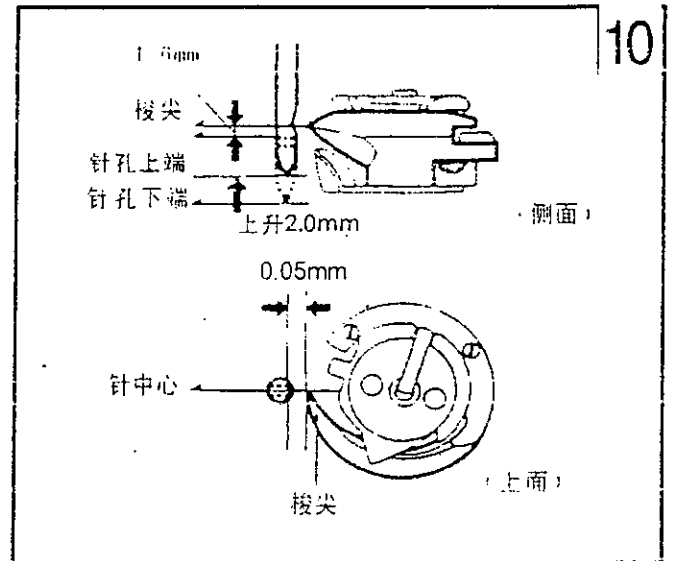

## 故障分析及處理方法 TROUBLE, CAUSE & REMEDY

常見故障 Trouble	產生原因 Cause	處理方法 Remedy
跳針 Stitch Dropping	<p>(1)由機針引起的： 機針彎曲 機針與縫綫規格不符</p> <p>(2)由機針安裝錯誤引起的： 插入不足 插入偏針</p> <p>(1)Reasons caused by needle Needle curving Needle not fit the thickness of thread.</p> <p>(2)Reasons caused by wrongly installing needle. When inserting needle, the depth of it is not enough. When inserting needle, the needle is inclined.</p>	<p>換機針。 換上與縫綫粗細相符的機針。</p> <p>插入至針杆的定位面。 重新裝機針。</p> <p>Replace needle Replace a needle which fit the thickness of thread. Insert needle to the fixed-position plane of needle bar. Re-installing needle.</p>
浮綫 Thread floating	<p>(1)面綫張力過鬆 (2)挑綫簧過鬆 (3)底綫張力過大</p> <p>(1)Tension of needle thread is too small. (2)Take-up spring is too loosen. (3)Tension of bobbin thread is too big.</p>	<p>把夾綫調節螺母順時針方向旋轉，調整面綫。 調節挑綫簧張力，縫厚料(針距長)時，應增強張力旋緊鬆心套梭皮螺釘來調節。</p> <p>Turn round tension adjusting nut clockwise to regulate needle thread. Adjusting the tension of take-up spring, when sewing thicker material (stitch length is long), the tension of take-up spring should be increased. Tighten the spring plate screw of hook case.</p>
斷綫 Thread breaking	<p>(1)縫綫質量低劣 (2)由機針引起 機針彎曲 安裝有誤 機針過細(相對縫綫來說)</p> <p>(3)面綫張力過緊</p> <p>(1)The quality of thread is pool.. (2)Caused by needle Needle curving Needle installing wrong Needle is too small (compared with thread) (3)The tension of needle thread is too big.</p>	<p>換上優質縫綫。粗細不均，有接頭的縫綫不能使用。</p> <p>換新機針。 重新裝機針。 換上與縫綫粗細相符的機針。 調鬆夾綫螺母。</p> <p>Replace thread which is very good. if the thickness of thread is not even or there is some joint in thread, do not use it. Replace a new needle. Re-installing needle. Replace a needle which fit the thickness of thread. Looseing threading nut.</p>



# CONTENTS 目次

MAIN FRAME AND COVER PARTS FOR 8810, 8820 本體機構和護蓋零件 .....	1
THREAD TENSION MECHANISM FOR 8810, 8820 縫綫調整機構 .....	3
SINGLE DIRECTION BEARING SHAFT MECHANISM 單向培林軸機構 .....	5
ROLLER PRESSER FOOT MECHANISM FOR 8810, 8820 輪綫組機構 .....	7
THREAD TAKE-UP LEVER MECHANISM 天秤機構 .....	9
UPPER SHAFT AND BALANCE WHEEL MECHANISM 上軸、皮帶輪機構 .....	11
UPPER SIDE SHAFT MECHANISM 上軸心機構 .....	13
NEEDLE BAR MECHANISM 針構機構 .....	15
NEEDLE BAR FEED MECHANISM 針棒進給機構 .....	17
PRESSER FOOT BAR MECHANISM 押棒機構 .....	19
TIMING BELT DRIVING MECHANISM FOR 8810, 8820 皮帶傳動機構 .....	21
STITCH ADJUSTER MECHANISM 縫目調整機構 .....	23
FEED SHAFT MECHANISM 輸送傳動機構 .....	25
CLUTCH SET MECHANISM 離合器機構 .....	27
BEDPLATE FEED MECHANISM FOR 8810 單針中座機構 .....	29
BEDPLATE GEAR FEED MECHANISM FOR 8810 中座齒輪傳動機構 .....	31
LEFT AND MIDDLE FEED MECHANISM FOR 8820 左邊座和中座傳動機構 .....	33
LEFT BEDPLATE FEED MECHANISM FOR 8820 左邊座傳動機構 .....	35
RIGHT SIDE BRACKET MECHANISM FOR 8810, 8820 右邊座傳動機構 .....	37
FEED MECHANISM FOR 8810, 8820 單向齒輪傳動機構 .....	39
RIGHT BEDPLATE FEED MECHANISM FOR 8810, 8820 右邊座傳動機構 .....	41
SPECIAL PARTS 特殊配件 .....	43
ACCESSORIES FOR 8810, 8820 附件 .....	45
FOR 8820 PRESSER FEET 壓腳 .....	47

## 本體機構和護蓋零件

Ref.No	Part No.	Name Of Part	Amt. req.		Remarks
			8810	8820	
1	XFS-119687	Face Plate 面蓋	1	1	
2	XFS-108246	Screw 螺絲	1	1	
3	XFS-108234	Screw 螺絲	1	1	
4	XFS-168061	Thread Take-up Cover 大平蓋	1	1	
5	XFS-210210	Screw 螺絲	1	1	
6	XFS-119027	4 Hole Thread Retainer 四孔過綫杆	1	1	
7	XFS-314946	Screw 螺絲	1	1	
8	XFS-119039	Arm Side Cover 大防砂板	1	1	
9	XFS-700335	Screw 螺絲	2	2	
10	XFS-118430	Thread Guide Wire 過綫杆	1	1	
11	XFS-700335	Screw 螺絲	1	1	
14	XFS-119686	Thread Guide Wire 過綫杆	1	1	
15	XFS-700335	Screw 螺絲	1	1	
16	XFS-119092	Bracket 固定腳器	1	1	
17	XFS-108285-i	Screw 螺絲	2	2	
18	XFS-119091	Bottom Cover 底座盤	1	1	
19	XFS-108225	Screw 螺絲	5	5	

本體機構和護蓋零件

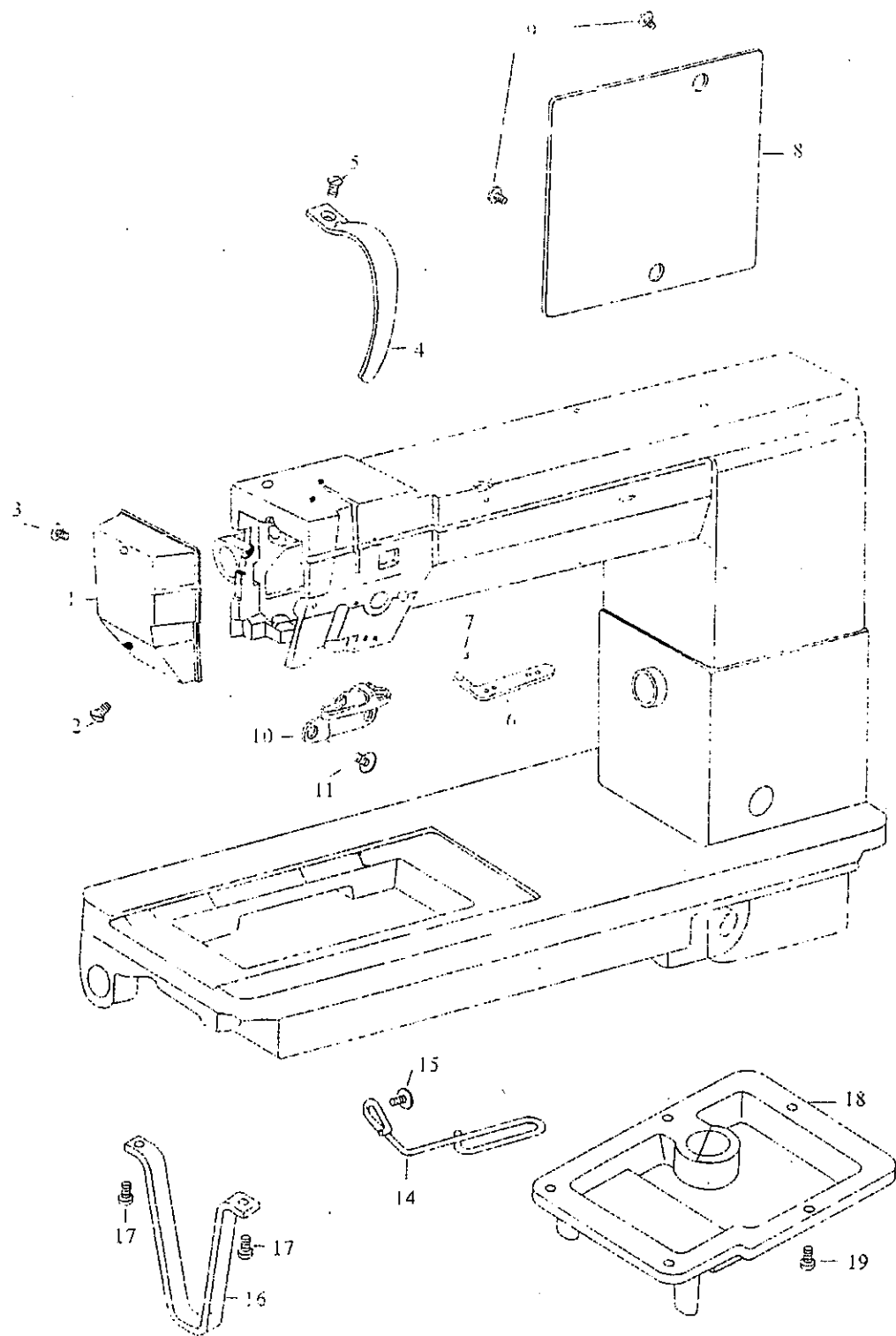

縫綫調整機構

Ref.No	Part No.	Name Of Part	Amt. req.		Remarks
			8810	8820	
1	XFS-118553	Tension Releasing Pin 松綫梢	1	1	(3-1--21)
2	XFS-119171	Thread Tension Regulator Assy 雙針沙拉組	0	1	
2-1	XFS-119171-1	Nut 螺帽	2	2	
2-2	XFS-119171-2	Spring Guide Assy 過綫盤組	1	2	
2-3	XFS-119171-3	Tension Spring 調整彈簧	1	2	
2-4	XFS-119171-4	Tension Take-up Spring 吊綫彈簧	1	1	
2-5	XFS-119171-5	Tension Disc 壓綫盤	2	4	
2-6	XFS-119171-6	Thread Tension Stud 調整螺絲杆	1	1	
2-7	XFS-119171-7	Screw 螺絲	1	1	
2-8	XFS-119171-8	Thread Tension Regulator Bushing 彈簧座	1	1	
2-9	XFS-119171-9	Tension Releasing Pin 松綫梢	1	1	
2-10	XFS-119171-10	Tension Releasing Pin 松綫梢	1	1	
2-11	XFS-119171-11	Tension Release Plate 彈簧板	1	1	
2-12	XFS-119171-12	Screw 螺絲	2	2	
2-13	XFS-119171-13	Tension Release Spring 壓板彈簧	1	1	
2-14	XFS-119171-14	Nut 螺帽	1	1	
2-15	XFS-119171-15	Upper Thread Tension Plate 上綫壓力板	1	1	
2-16	XFS-119171-16	Thread Tension Stud 調整螺絲杆	1	2	
2-17	XFS-119171-17	Thread Guide Bracket 過綫孔臺	1	2	
2-18	XFS-119171-18	Thread Guide Disc 過綫孔圓盤	1	2	
2-19	XFS-119171-19	Thread Guide Spring 道綫彈簧	1	2	
2-20	XFS-119171-20	Thread Guide Cap 過綫孔內蓋	1	2	
2-21	XFS-119171-21	Screw 螺絲	1	2	
2-22	XFS-119171-22	Tension Disc Washer 綫調整壓盤	1	2	
2-23	XFS-119171-23	Screw 螺絲	1	0	
2-24	XFS-119171-24	Screw 螺絲	0	1	
3	XFS-119766	Thread Tension Regulator Assy 單針沙拉組	1	0	(3-1--21)
3-4	XFS-119766-1	Tension Take -up Spring 吊綫彈簧	1	0	
4	XFS-175096-1	Screw 螺絲	1	1	
5	XFS-700412	Screw 螺絲	1	1	
6	XFS-700412-1	Bushing 襯套環	1	1	

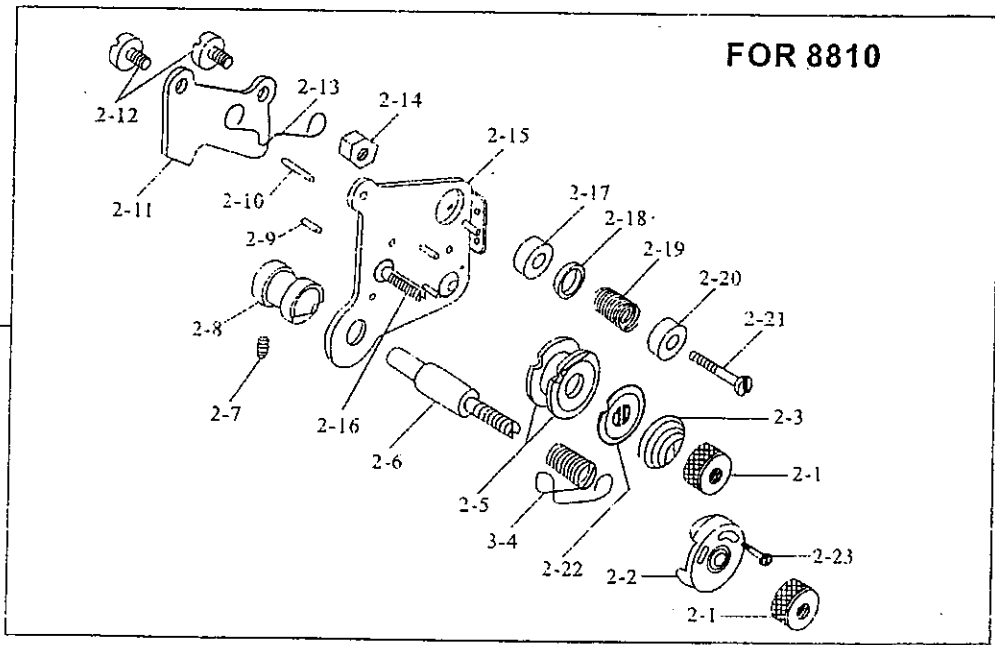
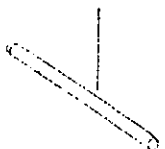
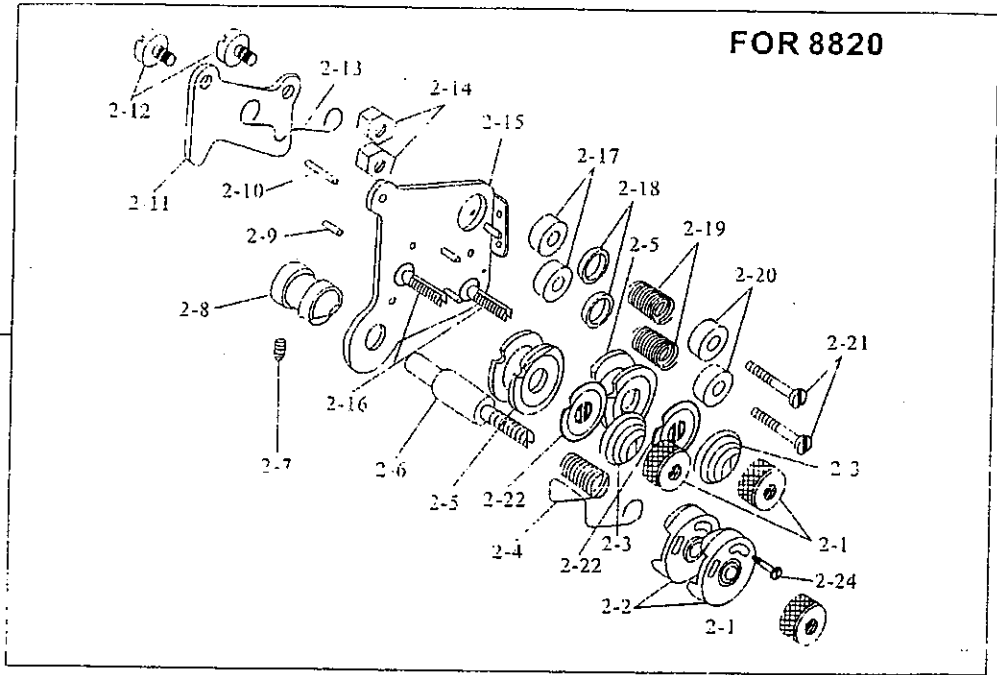

## 單向培林軸機構

Ref.No	Part No.	Name Of Part		Amt. req.		Remarks
				8810	8820	
1	XFS-660290	Retaining Ring	C型扣環	2	2	(1~3)
2	XFS-119158	Bearing Bracket	萬向培林座	1	1	
	XFS-119158-1	Bearing Bracket	(For XFS - 119803)	1	1	
3	XFS-756901	Bearing	培林	1	1	
4	XFS-119150	Bearing Set	萬向培林組	1	1	
	XFS-119150-1	Bearing Set	(For XFS - 119150)	1	1	
5	XFS-108294	Screw	螺絲	1	1	
6	XFS-640210	E-Ring	E型扣環	4	4	
7	XFS-119159	Washer(1.0)	華司	2	2	
7-1	XFS-119160	Washer(1.4)	華司	2	2	
8	XFS-119886	Washer(0.1)	華司	2	2	
8-1	XFS-119961	Washer(0.15)	華司	2	2	
8-2	XFS-119962	Washer(0.2)	華司	3	3	
8-3	XFS-119963	Washer(0.05)	華司	2	2	
9	XFS-119507	Link	萬向連杆	2	2	
10	XFS-174176	Screw	螺絲	4	4	
11	XFS-119087	Oil Felt	油棉墊	4	4	
12	XFS-061014	Needle Bearing	針狀培林	2	2	
13	XFS-119505	Free-wheeling	單向培林座	2	2	(12,13)
14	XFS-119506	Free Bearing	單向培林組	2	2	
15	XFS-119503	Shaft	單向培林軸	1	1	

單向培林軸機構

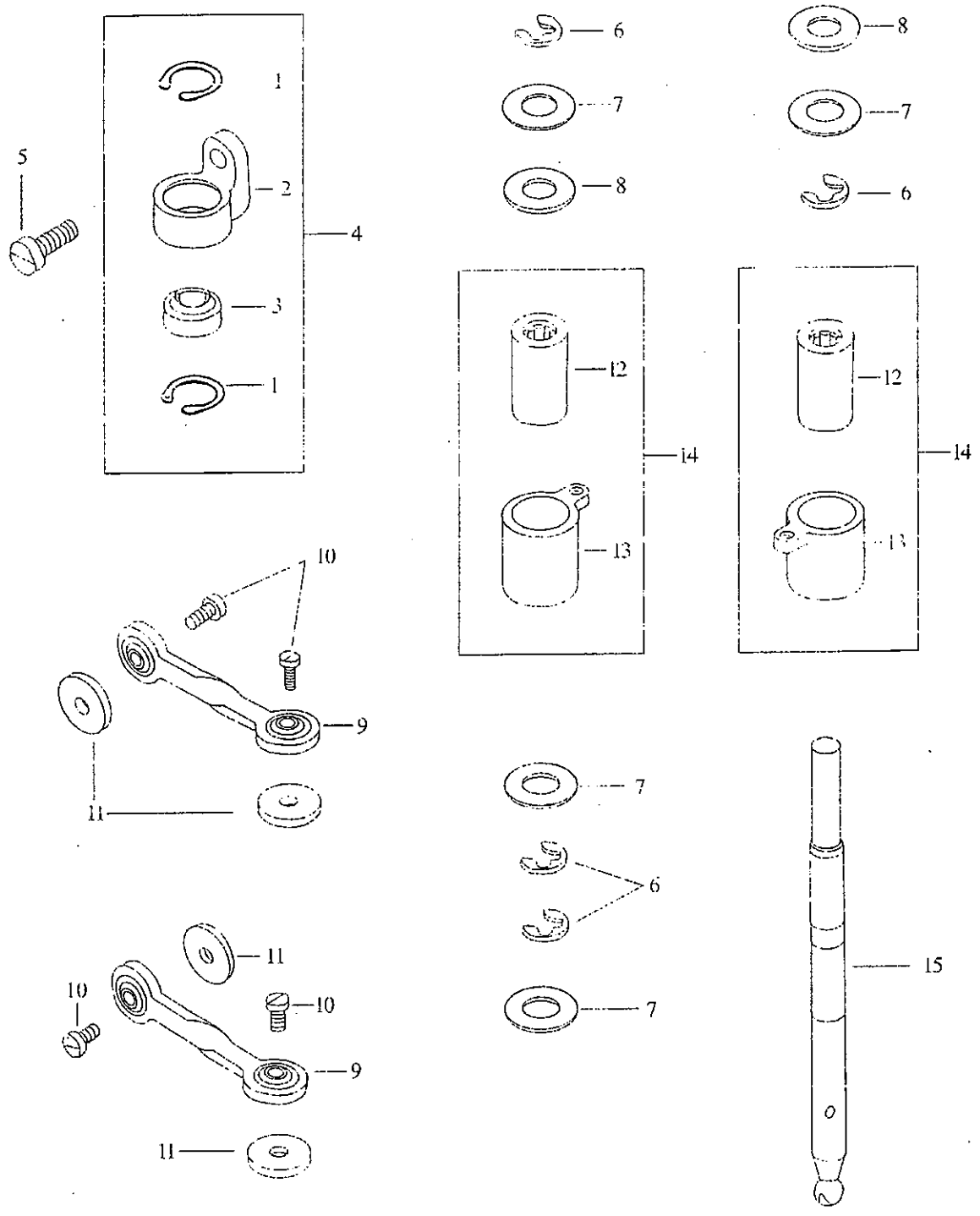

輪綫組機構

Ref.No	Part No.	Name Of Part	Amt. req.		Remarks
			8810	8820	
1	XFS-119803	Roller Presser Assy.(Large) 輪綫組(大)	1	1	
2	XFS-119803-1	Roller Presser Assy.(Middle) 輪綫組(中)	1	1	
3	XFS-119802	Roller Presser Assy.(Small) 輪綫組(小)	1	1	
4	XFS-119469	Spring Washer 止輪環	1	1	
5	XFS-033145	Pin 平行梢	1	1	
6	XFS-175109	Gear 齒輪	1	1	
6-1	XFS-175109-1	Gear Presser Shaft 傳動軸	1	1	
6-2	XFS-175109-2	Gear 齒輪盤	1	1	
6-3	XFS-175109-3	Gear Presser Shaft Seat(front) 輪綫軸座(前)	1	1	
6-4	XFS-175109-4	Gear Presser Shaft Seat 輪綫軸座(后)	1	1	
6-5	XFS-175109-5	Ball 鋼珠	1	1	
6-6	XFS-175109-6	Screw 螺絲	1	1	
6-7	XFS-175109-7	Screw 螺絲	1	1	
7	XFS-175107	Gear 齒輪	1	1	
7-1	XFS-175107-1	Gear Presser Shaft 傳動軸	1	1	
7-2	XFS-175107-2	Gear 齒輪盤	1	1	
7-3	XFS-175107-3	Gear Presser Shaft Seat 輪綫軸座	1	1	
8	XFS-175108	Gear 齒輪	1	1	
8-1	XFS-175108-1	Gear Presser Shaft 傳動軸	1	1	
8-2	XFS-175108-2	Gear 齒輪盤	1	1	
8-3	XFS-175108-3	Gear Presser Shaft Seat 輪綫軸座	1	1	
9	XFS-664290	Retaining Ring C型扣環	1	1	
10	XFS-133116	Ball Bearing 滾珠軸承	1	1	
10-1	XFS-133116-1	Washer 華司	1	2	
11	XFS-518210	Retaining Ring C型扣環	1	1	
12	XFS-119953	Roller Presser Bracket 輪綫座	1	1	
13	XFS-119943	Roller Presser Bracket 輪綫座	1	1	
14	XFS-119956	Roller Presser Bracket 輪綫座	1	1	
15	XFS-210043	Screw 螺絲	1	1	
16	XFS-119491	Washer 華司	1	1	
17	XFS-119807	Guide Seat 輪綫連接座(大)	1	1	
18	XFS-119955	Guide Seat 輪綫連接座(中)	1	1	
19	XFS-119954	Guide Seat 輪綫連接座(小)	1	1	
20	XFS-173174	Screw 螺絲	2	1	



輪綫組機構

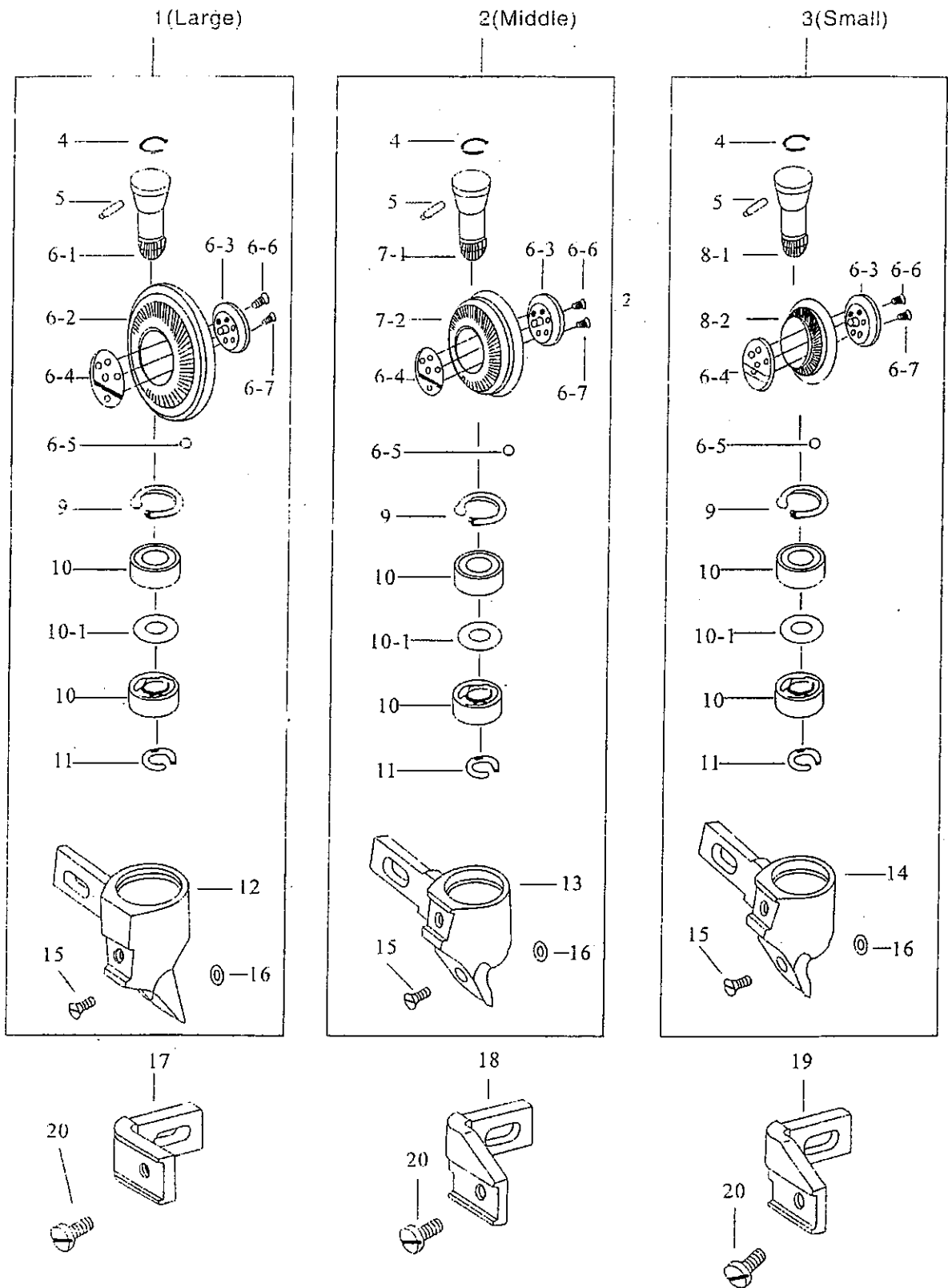

天秤機構

Ref.No	Part No.	Name Of Part	Amt. req.		Remarks	
			8810	8820		
1	XFS-118084	Thread Take -up Assy 天秤組	1	1	(2-19)	
2	XFS-119009	Take -up Lever Support Stud 天秤拉基軸	1	1		
3	XFS-168039	Washer 定環	2	2		
4	XFS-215022	Needle Bearing 針狀培林	2	2		
5	XFS-119008	Take-up Frame 天秤架	1	1		
6	XFS-119762	Take-up Crank Pin 天秤曲柄	1	1		
7	XFS-119049	Bushing 綫道	1	1		
8	XFS-119007	Take-up Lever 天秤杆	1	1		
9	XFS-167569	Ball Bearing 滾珠培林	1	1		
10	XFS-167570	Ball Bearing 滾珠培林	1	1		
11	XFS-119006	Take-up lever 天秤	1	1		(7-10)
12	XFS-168046	Washer 墊片	1	1		
13	XFS-168047	Screw 螺絲	1	1		
14	XFS-610210	Retaining Ring C型扣環	2	2		
15	XFS-039177	Screw 螺絲	1	1		
16	XFS-119013	Needle Bar Connecting Stud 針棒固定器	1	1		
17	XFS-119765	Needle Bar Connecting Crank Rod 針棒連接杆	1	1		
18	XFS-119763	Washer 華司	1	1		
19	XFS-218080	Needle Bearing 針狀培林	1	1		
20	XFS-118518	Needle Bar Guide Slide Block 針棒導引滑塊	1	1		
21	XFS-168041	Bushing 天秤軸套管	1	1		
22	XFS-314220	Screw 螺絲	3	3		

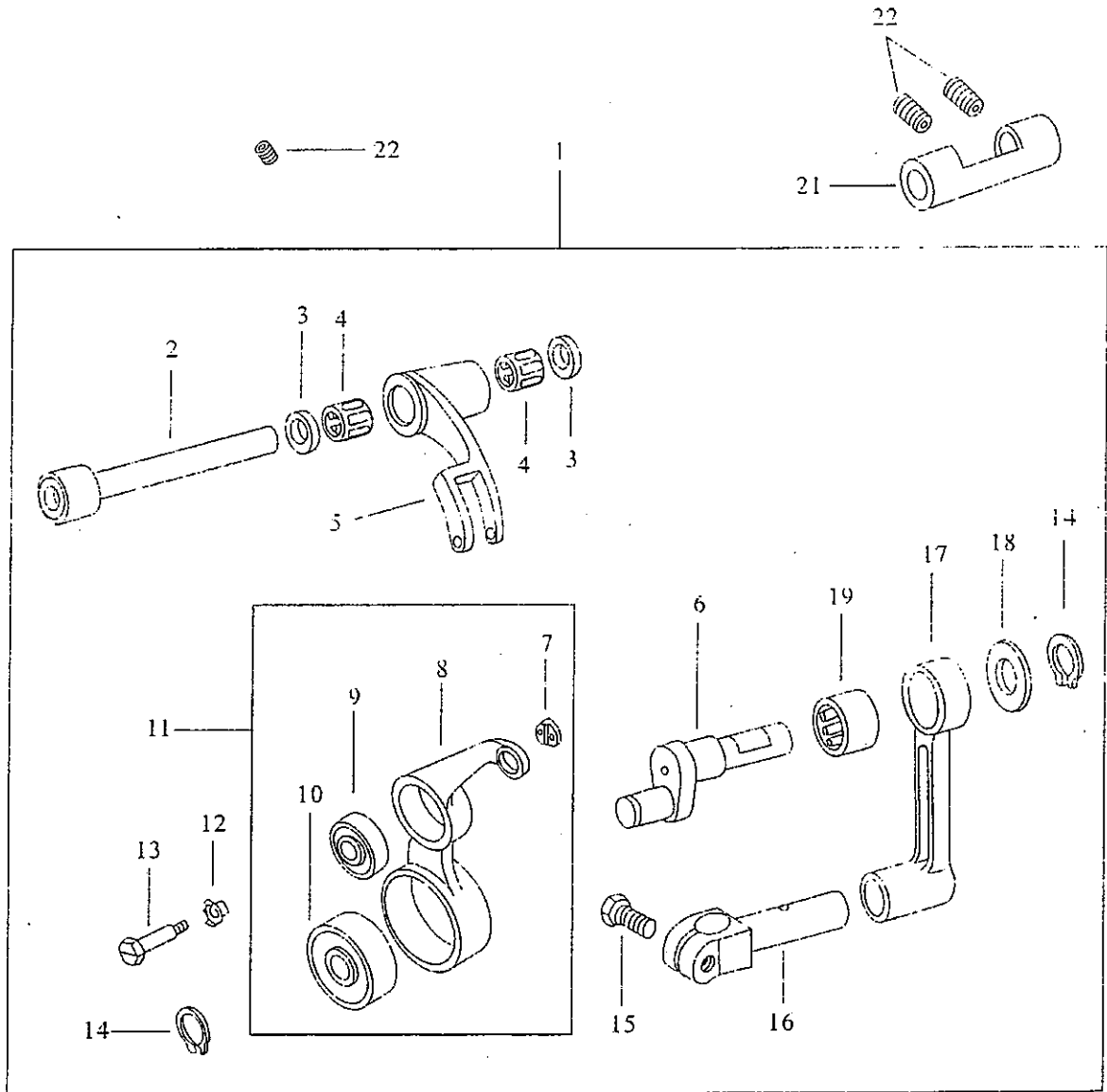

## 上軸、皮帶輪機構

Ref.No	Part No.	Name Of Part	Amt. req.		Remarks
			8810	8820	
1	XFS-119702-2	Crank Cam 凸輪	1	1	
2	XFS-130224	Screw 螺絲	2	2	
3	XFS-119702-3	Screw 螺絲	1	1	
4	XFS-119702-4	Screw 螺絲	1	1	
5	XFS-700510	Screw 螺絲	1	1	
6	XFS-119702-5	Bushing 上軸套環	1	1	
7	XFS-119702-1	Upper Shaft 上軸	1	1	
7-1	XFS-119702A	Upper Shaft Assy 上軸套環組	1	1	
8	XFS-119702-6	Bushing 套環	0	1	
9	XFS-018643	Ball Bearing 滾珠培林	1	1	
10	XFS-069160	Timing Belt 皮帶	1	1	
10-1	XFS-069160-1	Timing Belt 皮帶	1	1	
11	XFS-119707	Timing Belt Wheel 齒形皮帶輪	2	2	
12	XFS-335902	Screw 螺絲	2	2	
13	XFS-335902-1	Screw 螺絲	6	6	
14	XFS-016153	Ball Bearing 滾珠培林	2	2	
15	XFS-119705	Upper Shaft Bushing 上軸套管	2	2	
16	XFS-069746	Bushing 上軸套筒	1	1	
17	XFS-168480	Washer 墊司	2	2	
18	XFS-210265	Screw 螺絲	1	1	
19	XFS-175048	Feed Regulator Scale 縫日指示環	1	1	
20	XFS-170913	Pulley Balance Wheel 皮帶輪	1	1	
21	XFS-341902	Screw 螺絲	2	2	
22	XFS-210287	Screw 螺絲	1	1	

上軸、皮帶輪機構

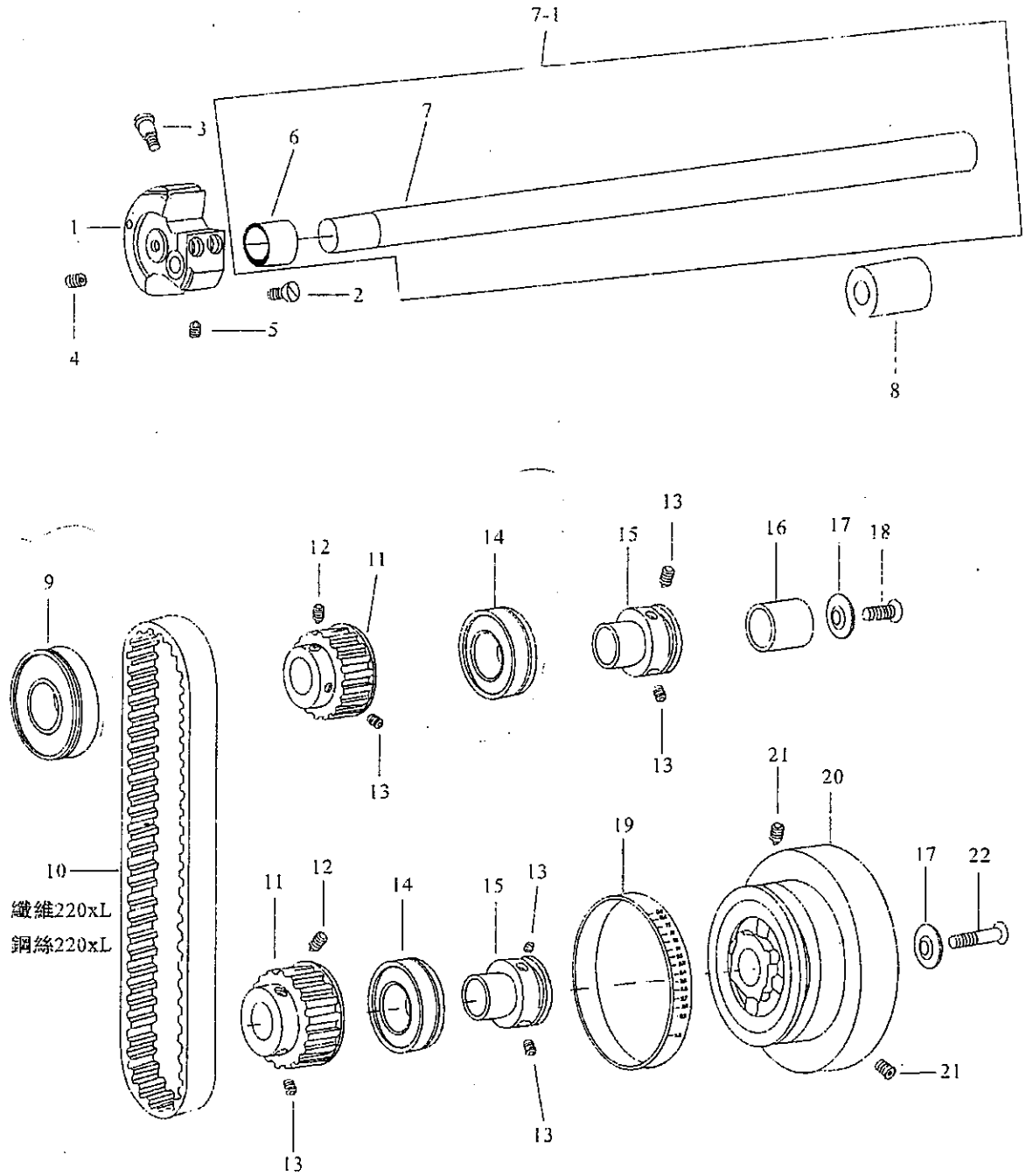

上軸心機構

Ref.No	Part No.	Name Of Part	Amt. req.		Remarks	
			8810	8820		
1	XFS-119164	Clamp	萬向連結座	1	1	(11)
2	XFS-108177	Screw	螺絲	1	1	
3	XFS-119163	Crank	萬向連結頭	1	1	
4	XFS-108225	Screw	螺絲	1	1	
5	XFS-119085	Washer	華絲	1	1	
6	XFS-119511	Upper Side Shaft	上邊軸	1	1	
7	XFS-118600	Bushing	針形軸承套管	2	2	
8	XFS-215124	Needle Breaing	針狀培林	2	2	
9	XFS-133283	Washer	華林	2	2	
10	XFS-118504	Collar	定環	1	1	
11	XFS-118503	Screw	螺絲	1	1	
12	XFS-610370	Retaining Ring	C型扣環	1	0	
13	XFS-119042-2	Eccentric With Road	凸輪連杆	1	0	
14	XFS-215028	Needle Bearing	針狀培林	1	0	
15	XFS-175150	Pin	固定梢(短)	1	0	
16	XFS-242810	Needle Bearing	針狀培林	1	0	
17	XFS-119042	Crank With Eccentric	小凸輪	1	1	
18	XFS-108225-2	Screw	螺絲	1	1	
19	XFS-130224	Screw	螺絲	1	1	

上軸心機構

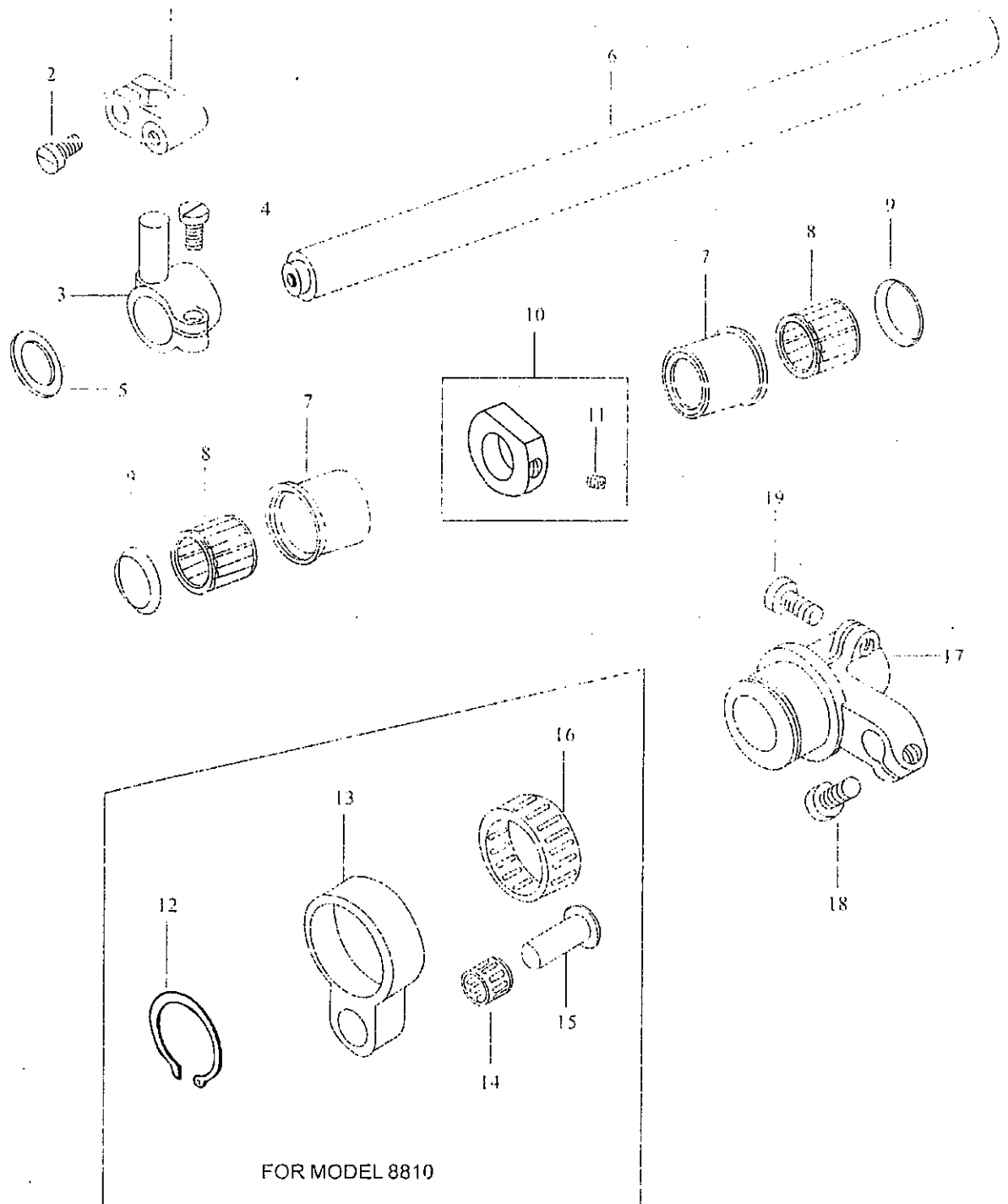

針構機構

Ref.No	Part No.	Name Of Part	Amt. req.		Remarks
			8810	8820	
1	XFS-118197	Needle Bar 雙針針棒	0	1	(4,5) (4,5) (24,25)
2	XFS-118196	Ring Clamp 針棒套環	0	1	
3	XFS-108174-1	Screw 螺絲	0	1	
4	XFS-700868	Screw 螺絲	0	1	
5	XFS-700868-1	Screw 螺絲	0	1	
6	XFS-118195	Needle Holder(2.8) 針榴	0	1	
	XFS-118195-1	Needle Holder(2.4) 針榴	0	1	
	XFS-118195-2	Needle Holder(3.2) 針榴	0	1	
7	XFS-175096	Needle Bar 單針針棒	1	0	
8	XFS-174173	Screw 螺絲	1	0	
9	XFS-175096-2	Thread Guide 針棒束環	1	0	
10	XFS-175150	Pin 固定梢(短)	1	1	
11	XFS-215028	Needle Bearing 針狀滾珠	2	2	
12	XFS-169137	Washer 墊圈	2	2	
13	XFS-305305	Screw 螺絲	2	2	
14	XFS-024191	Nut 螺帽	2	2	
15	XFS-118612	Pin 固定梢(長)	1	1	
16	XFS-119718	Shaft 腳押長軸	1	1	
17	XFS-030310	Pin 平行梢	1	1	
18	XFS-119046	Connecting Rod 連杆	1	1	
19	XFS-119525-2	Washer 華司	1	1	
20	XFS-119718-2	Retaining Ring C型扣環	1	1	
21	XFS-115585	Spring Plate 彈簧固定板	1	1	
22	XFS-108285	Screw 螺絲	1	1	
23	XFS-118857	Spring 彈簧	1	1	
24	XFS 118543	Crank 上下輪送臂	1	1	
25	XFS-118544	Pin 彈簧固定梢	1	1	
26	XFS-118543A	Crank Shaft 腳押連杆上下臂	1	1	
27	XFS-640150	E-Ring E型扣環	1	1	
28	XFS-020490	Spring Plate 彈簧勾板	1	1	
29	XFS-130224	Screw 螺絲	2	2	
29-1	XFS-130224-1	Screw 螺絲	1	1	
30	XFS-134356	Needle 針	1	1	
31	XFS-118545	Wsher 華司	1	1	



NEEDLE BAR MECHANISM

針構機構

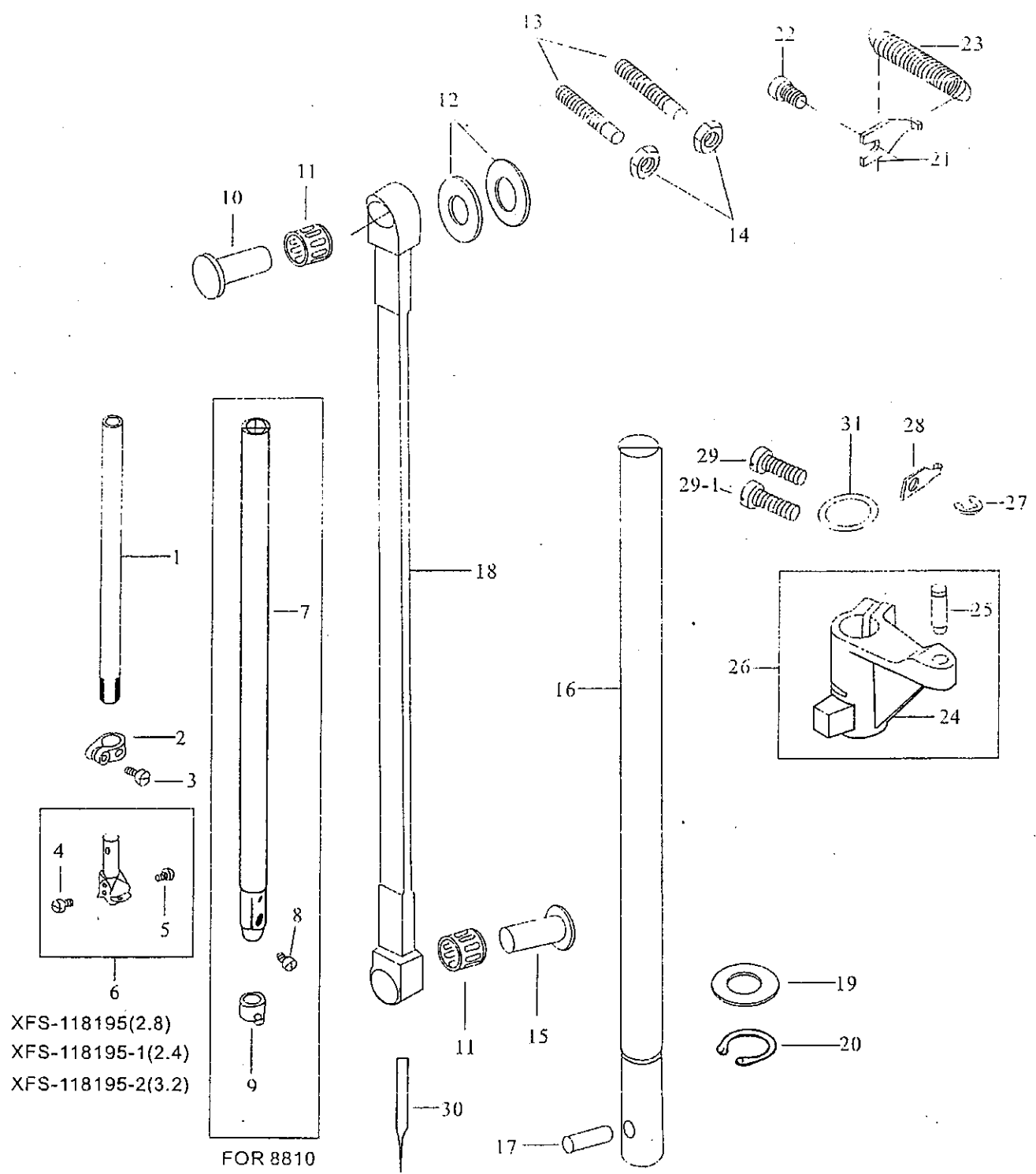

XFS-118195(2.8)  
XFS-118195-1(2.4)  
XFS-118195-2(3.2)

針棒進給機構

Ref.No	Part No.	Name Of Part	Amt. req.		Remarks
			8810	8820	
1	XFS-118600	Bushing 套管	2	0	
2	XFS-215124	Needle Bearing 針狀培林	2	0	
3	XFS-133283	Washer 華司	4	0	
4	XFS-118610	Crank 針送叉臂	1	0	
5	XFS-108285-1	Screw 螺絲	1	0	
6	XFS-130224	Screw 螺絲	1	0	
8	XFS-118594	Needle Bar Connecting Link Guide 針棒連接器導槽	1	1	
9	XFS-100355	Screw 螺絲	2	2	
10	XFS-119014	Oil Felt 油棉	1	1	
11	XFS-119015	Holder 油棉壓板	3	3	
12	XFS-706169	Screw 螺絲	2	2	
13	XFS-119940	Needle Bar Holder 針棒支撐座	1	1	
14	XFS-119940-5	Needle Bar Bushing 針棒導套(上)	1	1	
15	XFS-119940-4	Needle Bar Bushing 針棒導套(下)	1	1	
16	XFS-118521	Needle Bar Support Frame Retainer 針棒固定環	0	1	
17	XFS-108219	Screw 螺絲	0	1	
18	XFS-118520	Bushing 套管	0	1	
19	XFS-314280	Screw 螺絲	0	1	
20	XFS-118520-1	Bushing 套管	0	1	
21	XFS-118503	Screw 螺絲	1	1	
22	XFS-118504	Collar 定環	1	1	(21)

NEEDLE BAR FEED MECHANISM

針棒進給機構

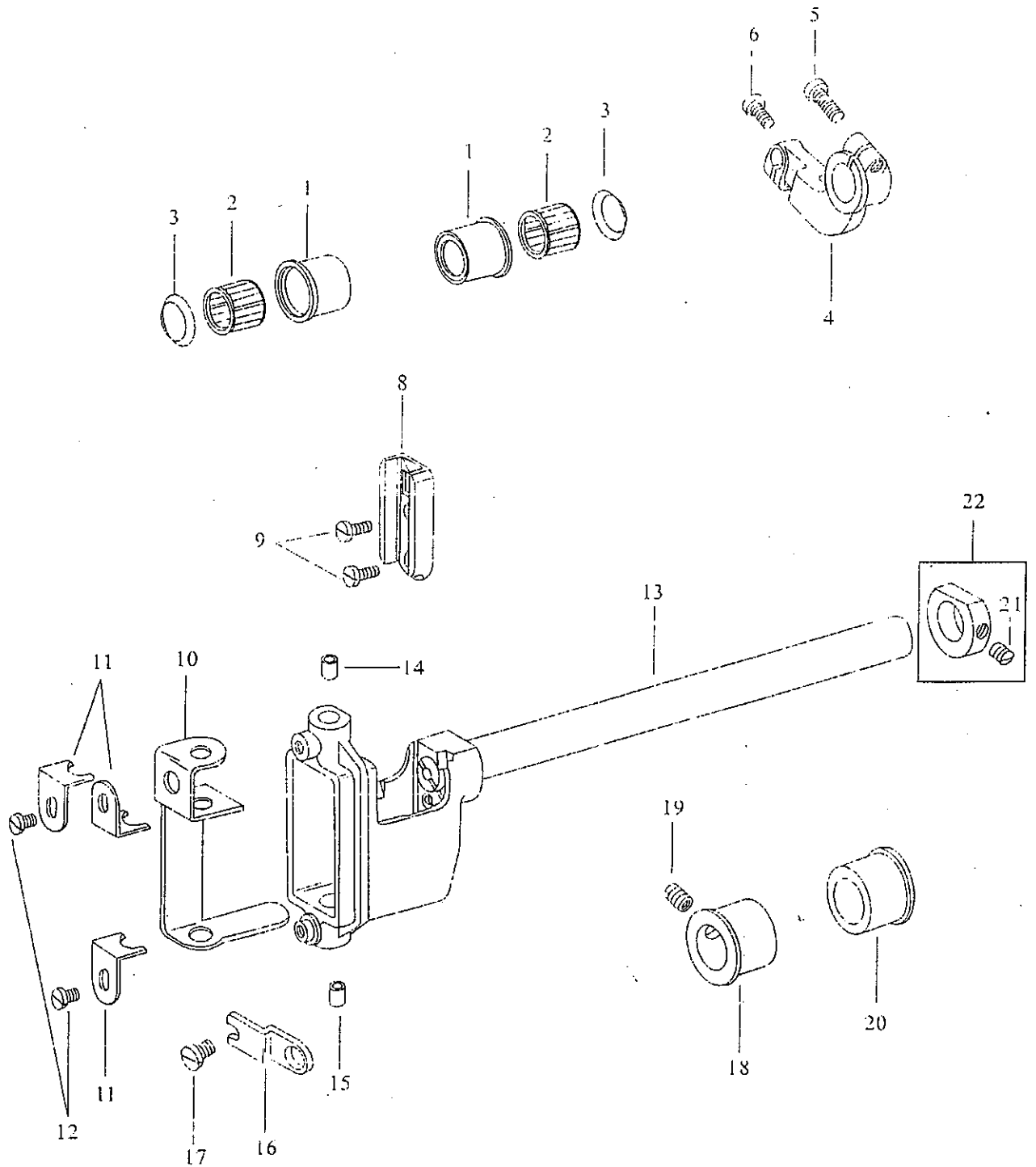

押棒機構

Ref.No	Part No.	Name Of Part	Amt. req.		Remarks	
			8810	8820		
1	XFS-119019	Presser Bar Bushing(Upper)	押棒套管 (上)	1	1	
2	XFS-700785	Screw	螺絲	1	1	
3	XFS-119018	Presser Bar	押棒	1	1	
3-1	XFS-119018-1	Pin	梢子	1	1	
4	XFS-118530	Presser Bar Holder	壓棒固定座	1	1	
5	XFS-700510	Screw	螺絲	2	2	
6	XFS-119019-1	Presser Bar Bushing(Lower)	押棒套管 (下)	1	1	
7	XFS-700510-1	Screw	螺絲	1	1	
8	XFS-119165-1	Roller Presser Holder	輪錢上座	1	1	
9	XFS-119165	Roller Presser Holder	輪錢下座	1	1	
10	XFS-173174	Screw	螺絲	1	1	
11	XFS-025874	Spring	彈簧	1	1	
12	XFS-054876	Angle	頂針座	1	1	
13	XFS-130173	Screw	螺絲	1	1	
14	XFS-175135	Cover	小防砂板	1	1	
15	XFS-700335	Screw	螺絲	2	2	
16	XFS-069079	Presser Foot Lifter	押棒提杆	1	1	
17	XFS-317950	Screw	螺絲	1	1	
18	XFS-119004	Bushing	押棒提杆套管	1	1	
19	XFS-118577	Cam Shaft	押棒提杆軸	1	1	
20	XFS-100331	Screw	螺絲	1	1	
21	XFS-118535	Presser Plate Spring	彈片壓板	1	1	
22	XFS-343901	Screw	螺絲	1	1	
23	XFS-118105	Stud	軌導棒	1	1	
24	XFS-314286	Screw	螺絲	1	1	
25	XFS-700017	Screw	螺絲	1	1	
26	XFS-119016	Spring	彈簧	1	1	
27	XFS-049657	Presser Foot	押脚	0	1	
	XFS-049657-1	Presser Foot	押脚	0	1	
28	XFS-108171	Screw	螺絲	0	1	
29	XFS-118542	Knee Lifter Connecting Lever	脚弓連接杠杆	1	1	
30	XFS-118536	Spring Plate	押上板	1	1	
31	XFS-118536-1	Pin	梢子	1	1	
32	XFS-118539	Bushing	套管	1	1	
33	XFS-640150	E-ring	E型扣環	1	1	
34	XFS-118536A	Lifting Lever Assy	押上板組	1	1	(30~33)
35	XFS-343902	Bushing	套環	1	1	

PRESSER FOOT BAR MECHANISM

押棒機構

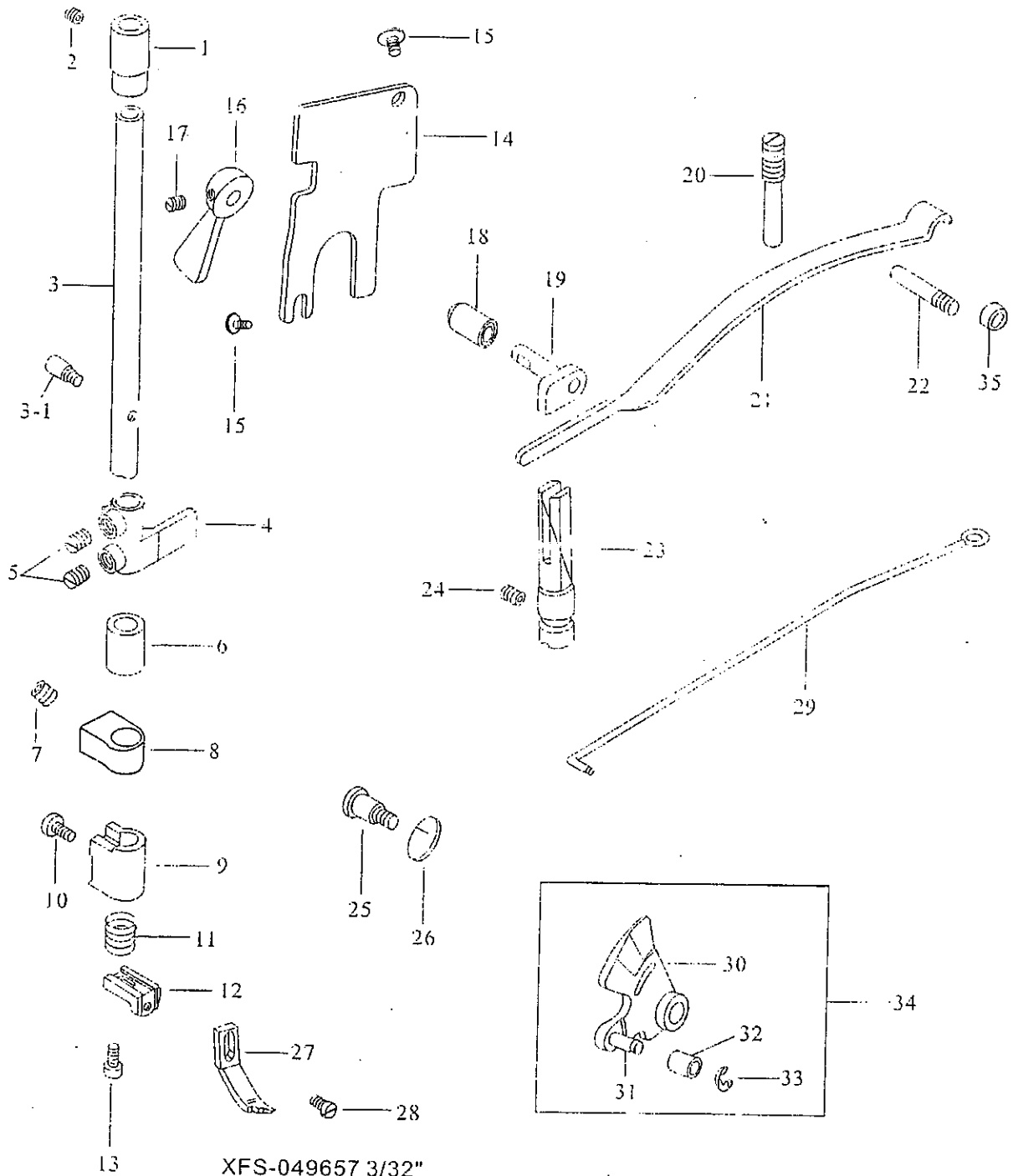

XFS-049657 3/32"  
XFS-049657-1 1/16"

皮帶傳動機構

Ref.No	Part No.	Name Of Part	Amt. req.		Remarks
			8810	8820	
1	XFS-119097	Plug 保護蓋	2	2	
2	XFS-610300	Retaining Ring C型扣環	1	1	
3	XFS-018624	Ball Bearing 滾珠軸承	2	2	
4	XFS-119707	Timing Belt Wheel 齒形皮帶輪	1	1	
5	XFS-335902 1	Screw 螺絲	2	2	
6	XFS-335902	Screw 螺絲	2	2	
7	XFS-119121	Collar(Left) 軸承套管 (左)	1	1	
8	XFS-700689	Screw 螺絲	4	4	
9	XFS-018613	Ball Bearing 滾珠軸承	1	1	
10	XFS-119708	Timing Belt Wheel 齒輪皮帶輪	1	1	
11	XFS-069161	Timing Belt 皮帶	1	1	
	XFS-069161-1	Timing Belt 皮帶	1	1	
12	XFS-119706	Shaft 皮帶輪軸	1	1	
13	XFS-118726	Collar(Right) 軸承套管 (右)	1	1	

皮帶傳動機構

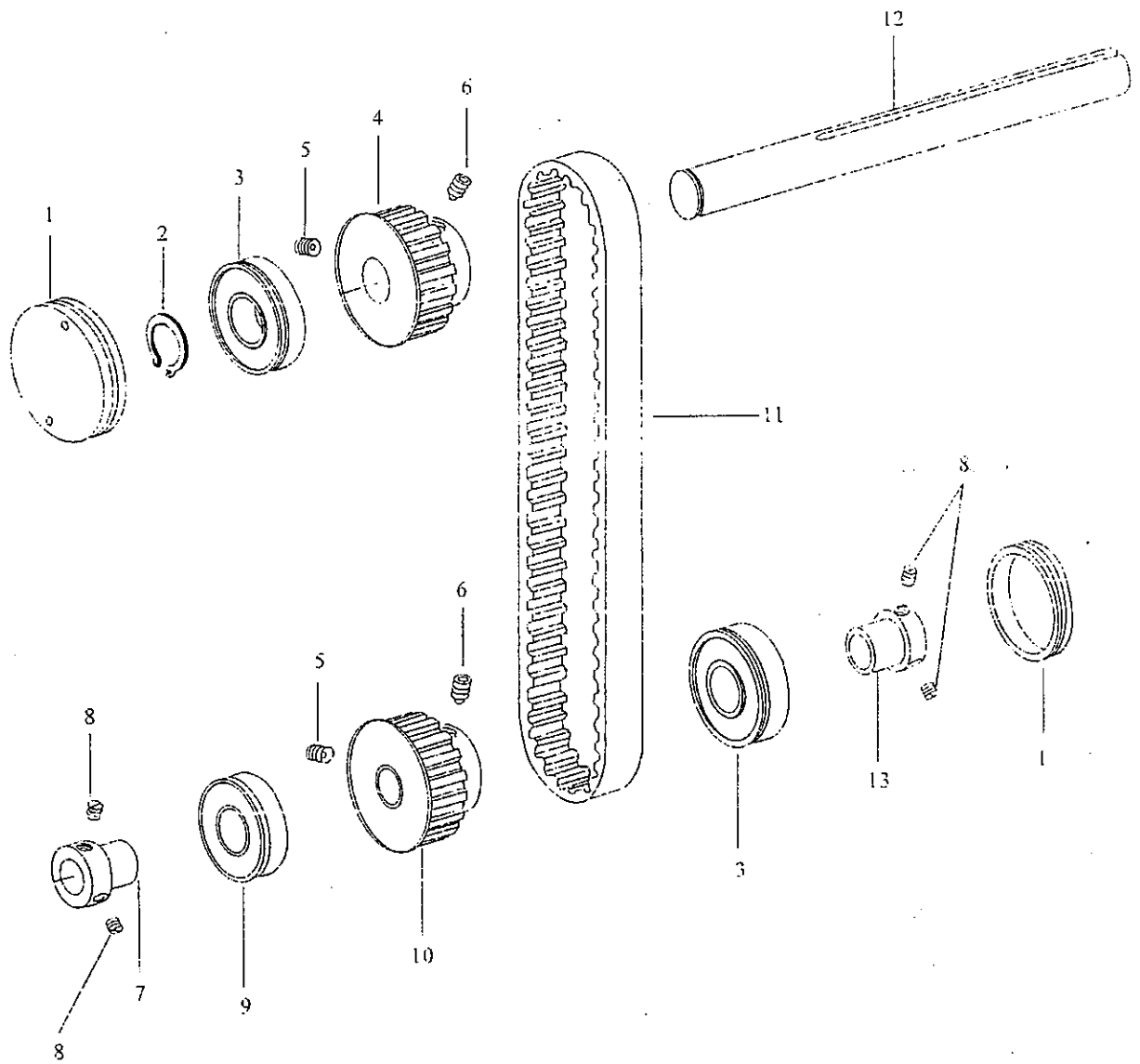

## 縫目調整機構

Ref.No	Part No.	Name Of Part	Amt. req.		Remarks
			8810	8820	
1	XFS-175038	Connecting Rod 連杆	1	1	(1, 2)
2	XFS-6906	Ball Bearing 滾珠軸承	1	1	
3	XFS-175038A	Crank Rod Set 毛毛連杆組	1	1	
4	XFS-215028	Needle Bearing 針狀軸承	1	1	
5	XFS-115012	Bearing Stud 固定銷 (長)	1	1	
6	XFS-165356	Feeding Adjusting Plate 送料調節板	1	1	
7	XFS-165356-1	Screw 螺絲	1	1	
8	XFS-165356-8	Nut 螺帽	1	1	
9	XFS-165356-5	Spring 彈簧	1	1	
10	XFS-165356-7	E-ring E型扣環	1	1	
11	XFS-165356-6	Spring 彈簧	1	1	
12	XFS-165356-2	Pin 梢子	1	1	
13	XFS-165356-3	Screw 螺絲	1	1	
14	XFS-175029	Cam Assy 凸輪組	1	1	
14-1	XFS-175029-1	Stitch Regulating Seat 縫目調整座	1	1	
14-2	XFS-175029-2	Stitch Regulating Fix Seat 縫目調整固定座	1	1	
14-3	XFS-175029-3	Feed Adjusting Fix Screw 偏心調整支軸	1	1	
14-4	XFS-175029-4	Screw 螺絲	1	1	
14-5	XFS-175029-5	Nut 螺帽	1	1	
14-6	XFS-175029-6	Friction Plate 迫緊片	1	1	
14-7	XFS-175029-7	Screw 螺絲	1	1	
14-8	XFS-175029-8	Screw 螺絲	1	1	
14-9	XFS-175029-9	Screw 螺絲	1	1	
14-10	XFS-175029-10	Eccentric Wheel 縫目調整偏心輪	1	1	
14-11	XFS-175029-11	Spring 彈簧	1	1	
14-12	XFS-175029-12	Collar 套環	1	1	
14-13	XFS-175029-13	Screw 螺絲	2	2	



縫目調整機構

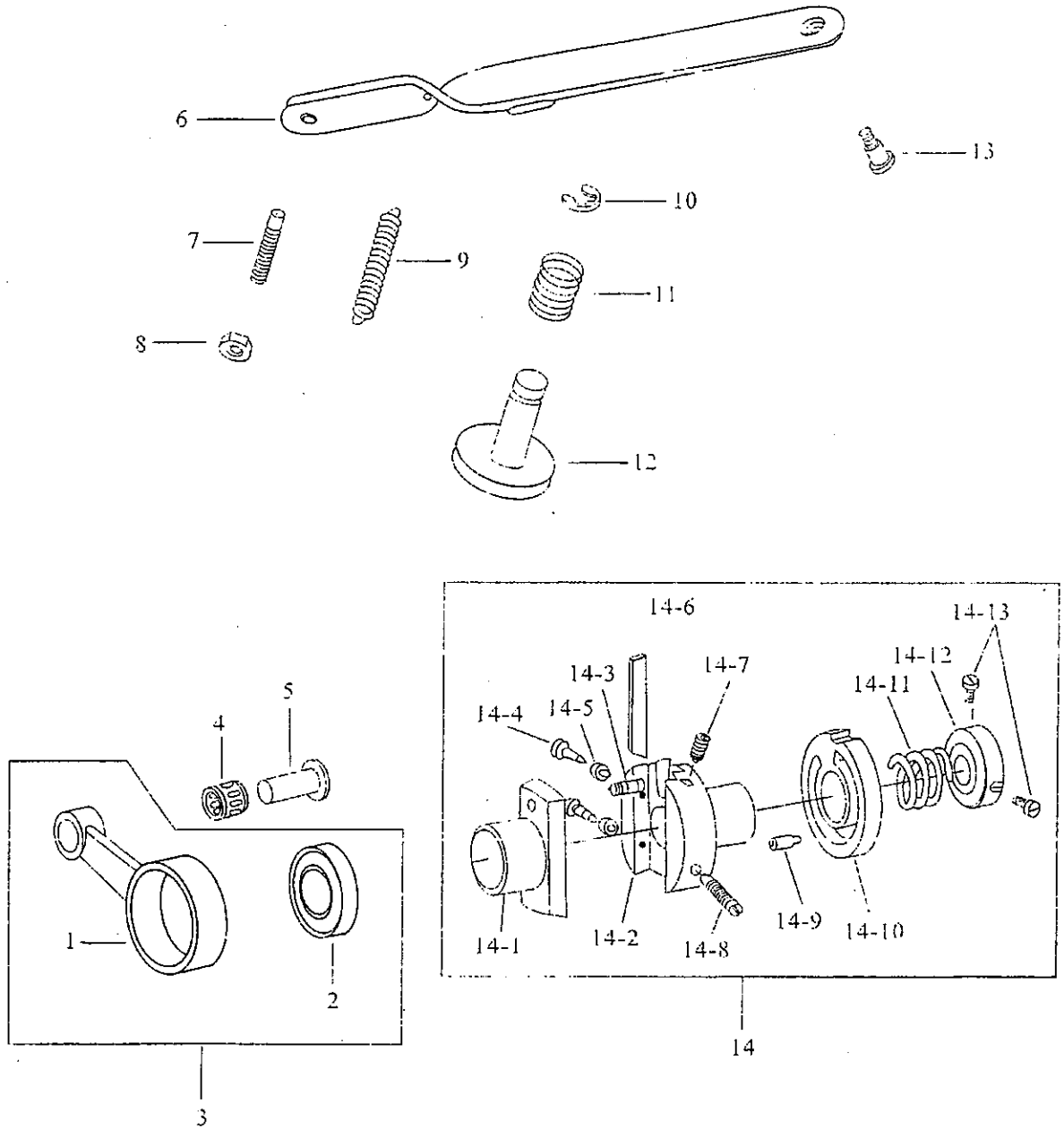

Ref No.	Part No.	Name Of Part	Amt. req.		Remarks	
			8810	8820		
1	XFS-610280	Retaining Ring	C型扣環	1	1	(16)
2	XFS-119085	Washer	華司	1	1	
3	XFS-133283	Washer	針狀軸承蓋	6	6	
4	XFS-215124	Needle Bearing	針狀軸承	3	3	
5	XFS-118600	Bushing	套管	1	1	
6	XFS-119163	Crank	萬向連結頭	1	1	
7	XFS-108225	Screw	螺絲	1	1	
8	XFS-119164	Clamp	萬向連結座	1	1	
9	XFS-108177	Screw	螺絲	1	1	
10	XFS-119084	Shaft	輸送主軸	1	1	
11	XFS-118601	Bushing	套管	1	1	
12	XFS-119521	Crank	單向輸送支臂	1	1	
13	XFS-130224	Screw	螺絲	3	3	
14	XFS-335902-1	Screw	螺絲	2	2	
15	XFS-119521-1	Crank	單向輸送支臂	1	1	
16	XFS-700689	Screw	螺絲	3	3	
17	XFS-118603	Bushing	套管	1	1	
18	XFS-119893	Collar	上邊心定環	1	1	

輸送傳動機構

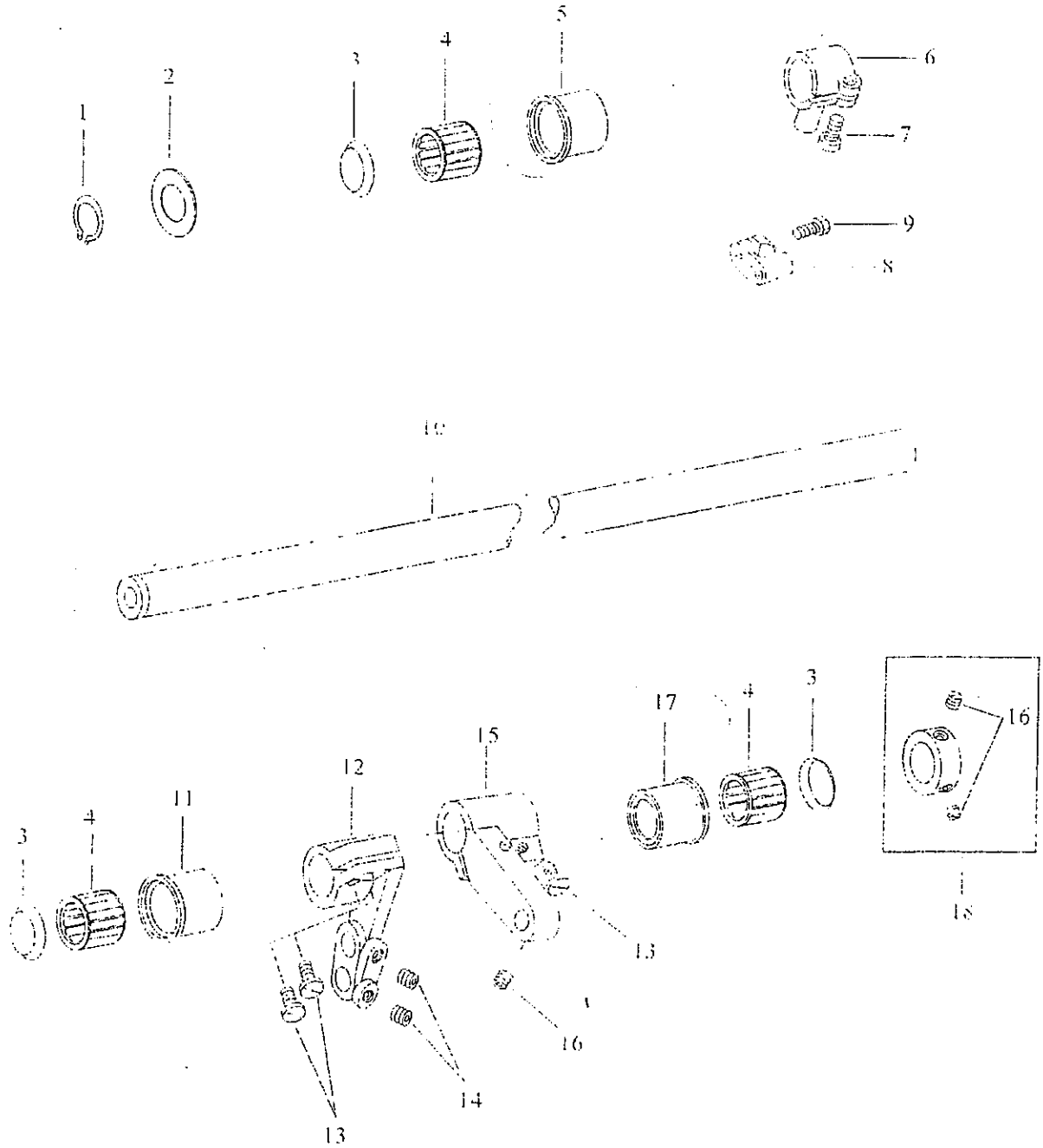

## 離合器機構

Ref No	Part No	Name Of Part	Amt req		Remarks	
			8810	8820		
1	XFS-175025	Shaft	萬向連結軸	1	1	(7-1~7-14)
2	XFS-518250	Retaining Ring	C型扣環	1	1	
3	XFS-119711	Shaft	萬向連結軸 (短)	1	1	
4	XFS-175019	Coupler	軸連器 (左)	1	1	
5	XFS-341901	Screw	螺絲	4	4	
6	XFS-133109	Connecting Plate	連接板	1	1	
7	XFS-119081A	Safety Clutch	離合器組	1	1	
7-1	XFS-700510	Screw	螺絲	2	2	
7-2	XFS-172263	Safety Clutch Seat	離合器座	1	1	
7-3	XFS-013153	Spring	彈簧	2	2	
7-4	XFS-173261	Latch	離合器爪	1	1	
7-5	XFS-009408	Hinge Stud	固定座	1	1	
7-6	XFS-173264	Coupler(right)	軸連器 (右)	1	1	
7-7	XFS-065052	Pin	平行梢	2	2	
7-8	XFS-640150	E-ring	E型扣環	1	1	
7-9	XFS-175023	Stud	彈簧固定套	2	2	
7-10	XFS-640130	E-ring	E型扣環	1	1	
7-11	XFS-013076	Drop-In Pin	固定梢	1	1	
7-12	XFS-009037	Washer	華司	1	1	
7-13	XFS-009343	Spring	壓縮彈簧	1	1	
7-14	XFS-175126	Ring	固定螺絲	1	1	

離合器機構

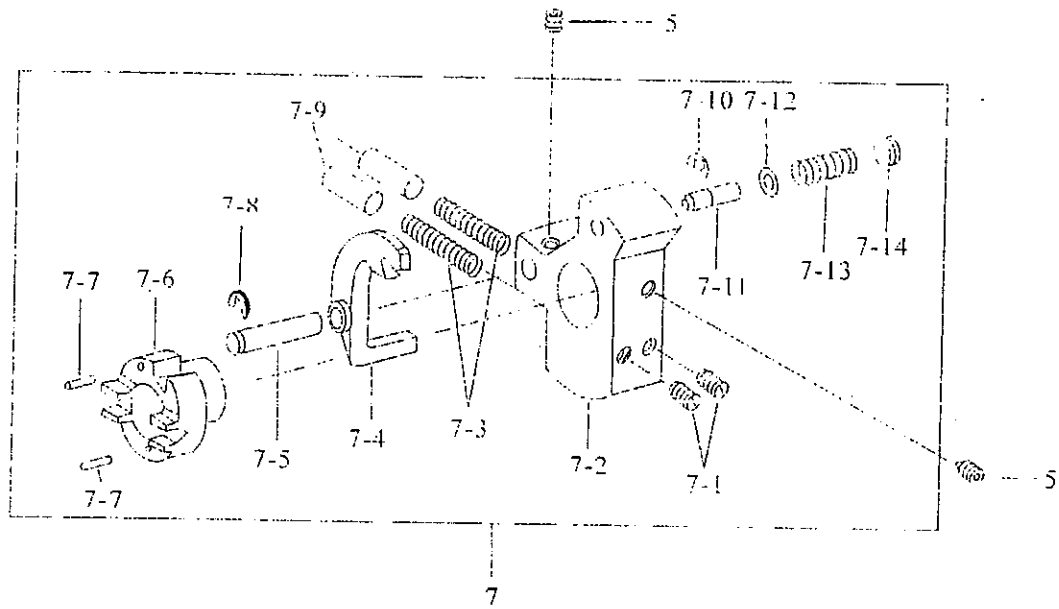
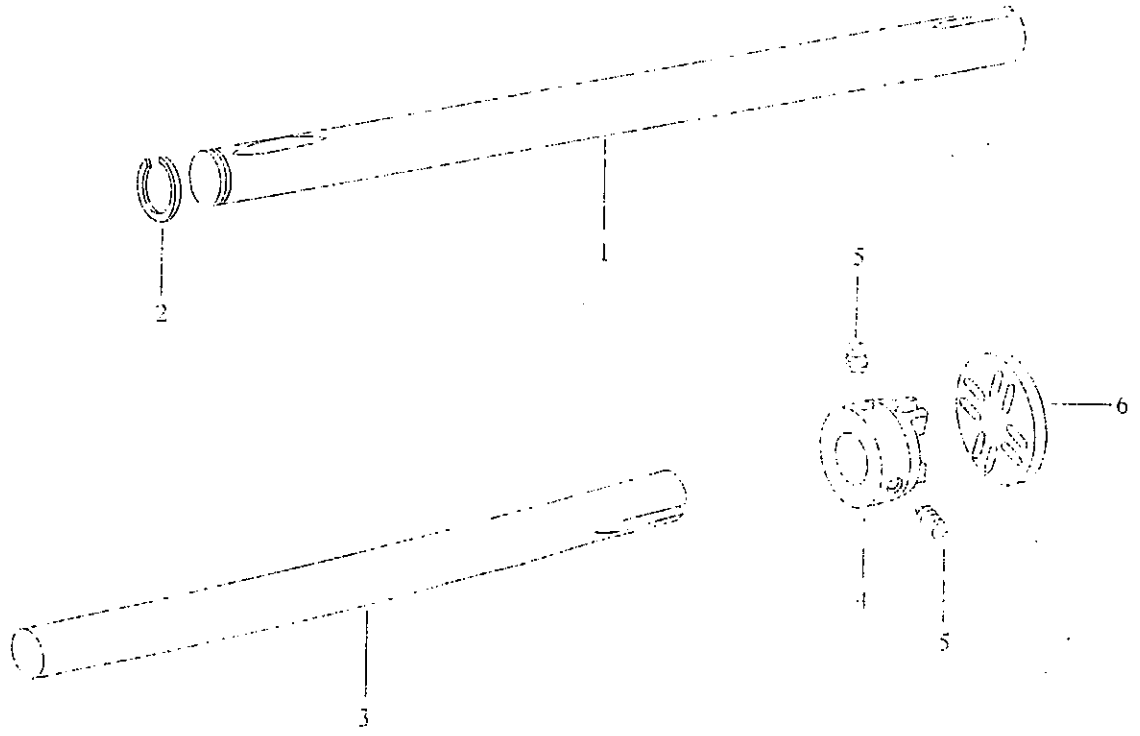

## 單針中座機構

Ref.No	Part No.	Name Of Part	Amt. req.		Remarks
			8810	8820	
1	XFS-119145	Cover Plate 邊蓋板	1	0	
2	XFS-250084	Screw 螺絲	4	0	
3	XFS-119721	Support Plate 單針中座	1	0	
4	XFS-119144	Washer 華司	2	0	
5	XFS-130224	Screw 螺絲	2	0	
6	XFS-182451	Screw 螺絲	1	0	
7	XFS-119725	Stud 調整梢	1	0	
8	XFS-317170	Screw 螺絲	1	0	
9	XFS-168351	Plug 油蓋	1	0	
10	XFS-305174	Washer 華司	4	0	
11	XFS-135292	Screw 螺絲	4	0	
12	XFS-119121	Collar 主軸套管	1	0	
13	XFS-700689	Screw 螺絲	2	0	
14	XFS-016120	Ball Bearing 滾珠軸承	1	0	
15	XFS-305144	Cover Plate 邊蓋板	1	0	
16	XFS-058436	Needle Plate(2.0) 單針針板	1	0	
	XFS-058436-1	Needle Plate(1.6) 單針針板	1	0	
17	XFS-210168	Screw 螺絲	2	0	

單針中座機構

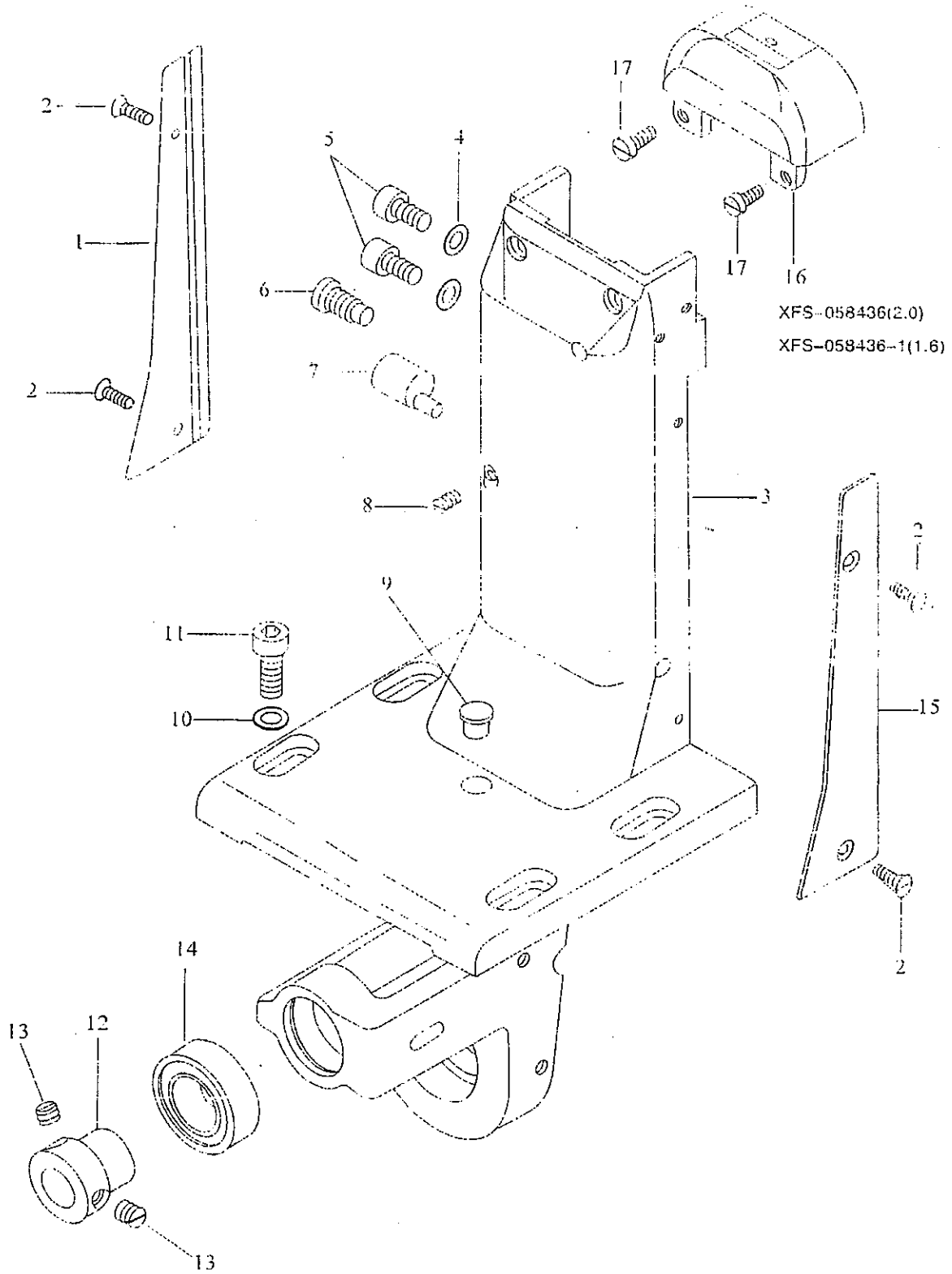

中座齒輪傳動機構

Ref.No	Part No.	Name Of Part	Amt. req.		Remarks
			8810	8820	
1	XFS-119795	Roller Bracket 送料齒輪軸	1	0	
1-1	XFS-119795-1	Roller Bracket(Upper) 送料齒輪軸(上)	1	0	
1-2	XFS-119795-2	Roller Bracket(lower) 送料齒輪軸(下)	1	0	
1-3	XFS-119795-3	Screw 螺絲	1	0	
1-4	XFS-119795-4	Screw 螺絲	1	0	
1-5	XFS-119795-5	Ball 鋼珠	24	0	
2	XFS-119737	Bevel Gear 上下送料齒輪	1	0	
2-1	XFS-119737-1	Roller Bracket 送料齒輪軸	1	1	
2-2	XFS-119737-2	Roller Bracket 送料大齒輪	1	1	
2-3	XFS-119737-3	Feed Wheel 送料輪	1	0	
3	XFS-119723	Bracket 過綫齒輪座	1	0	
3-1	XFS-119723-1	Screw 螺絲	1	0	
3-2	XFS-119723-2	Screw 螺絲	2	0	
4	XFS-119670	Coller 定環	1	0	
4-1	XFS-119670-1	Screw 螺絲	2	0	(1~5)
5	XFS-119724	Bushing 送料齒輪套環	1	0	
6	XFS-119723A	Bevel Gear Assy 送料齒輪組	1	0	
7	XFS-119535	Bushing 軸連接器	2	0	
8	XFS-119534	Clutch 塑膠接頭	1	0	
9	XFS-119535-1	Screw 螺絲	4	0	(7~9)
10	XFS-119535A	連杆接頭組	1	0	
11	XFS-119532	Shaft 中座軸	1	0	
11-1	XFS-119535-1	Screw 螺絲	2	0	
12	XFS-119533	Bushing 套管	1	0	
13	XFS-5045	Bevel Gear(small) 中座齒輪(小)	1	0	
14	XFS-5046	Bevel Gear(medium) 中座齒輪(中)	1	0	
15	XFS-700689	Screw 螺絲	4	0	(13~15)
16	XFS-175113	中座齒輪組	1	0	



中座齒輪傳動機構

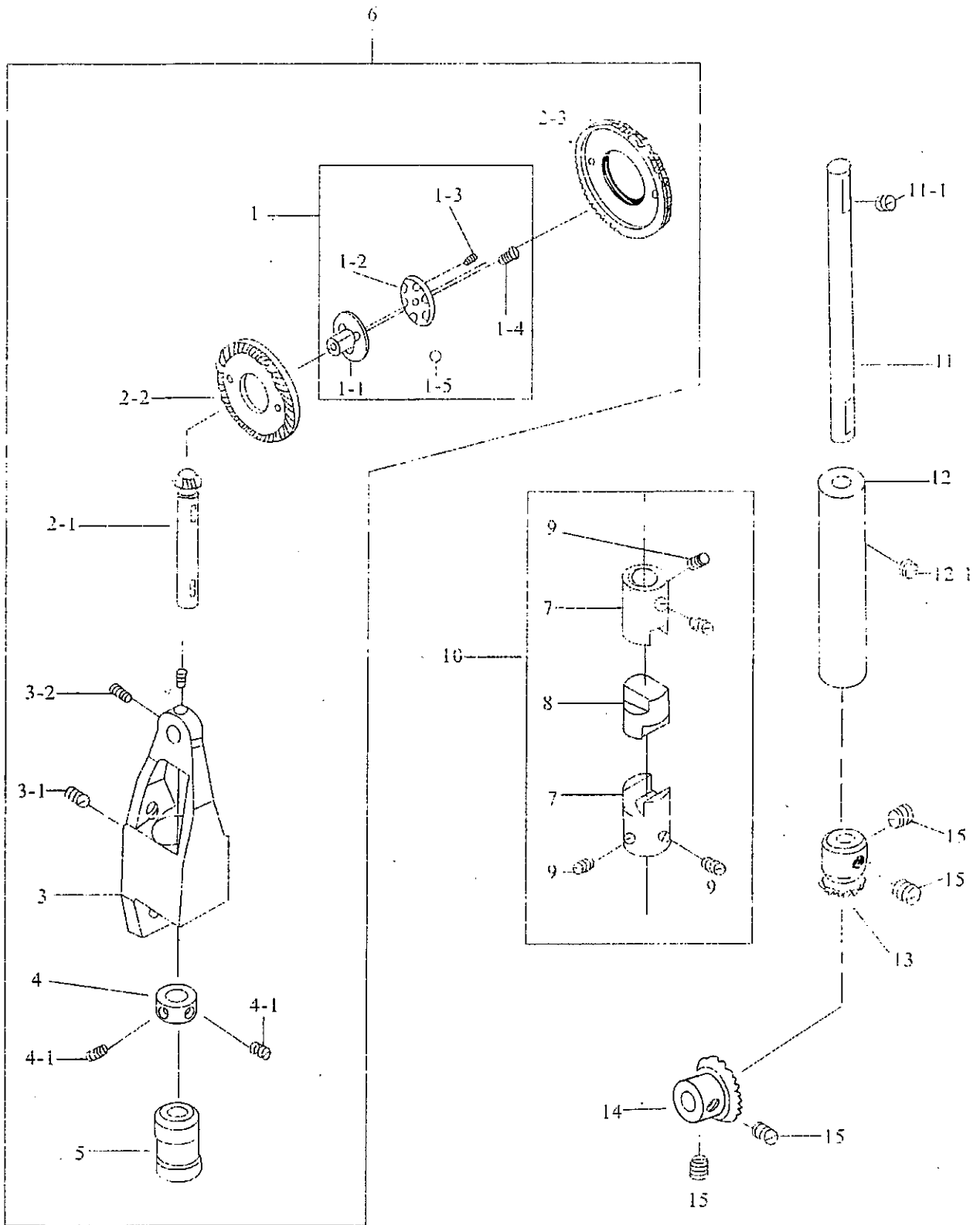

## 左邊座和中座傳動機構

Ref.No	Part No.	Name Of Part	Amt. req.		Remark
			8810	8820	
1	XFS-119976	Side Bracket ( Left ) 附耳邊座(左)	0	1	
2	XFS-119499	Cover Plate 邊蓋板	0	1	
3	XFS-250084	Screw 螺絲	0	4	
4	XFS-119695	Cover Plate 邊蓋板	0	1	
5	XFS-168351	Plug 油蓋	0	1	
6	XFS-135292	Screw 螺絲	0	4	
7	XFS-305174	Washer 橢圓華司	0	4	
8	XFS-016120	Ball Bearing 滾珠軸承	0	1	
9	XFS-119121	Collar 主軸套管	0	1	
10	XFS-700689	Screw 螺絲	0	2	
11	XFS-175318	Stud 調整梢	0	1	
12	XFS-119143	Spring Plate 彈簧板	0	1	
13	XFS-108093	Screw 螺絲	0	1	
14	XFS-119138	Bearing Plate 固定板	0	1	
15	XFS-119136	Feed Wheel 送料齒輪	0	1	
16	XFS-108174-1	Screw 螺絲	0	2	
17	XFS-119140	Post Cap Assy 斧蓋	0	2	
18	XFS-108093	Screw 螺絲	0	2	
19	XFS-058325	Needle Plate ( 2.4 ) 雙針針板	0	1	
	XFS-058325-1	Needle Plate(1.6) 雙針針板	0	1	
	XFS-058325-2	Needle Plate(2.0) 雙針針板	0	1	
20	XFS-100296	Screw 螺絲	0	2	
21	XFS-119296	Support Plate 雙針中座	0	1	
22	XFS-108174-1	Screw 螺絲	0	8	

左邊座和中座傳動機構

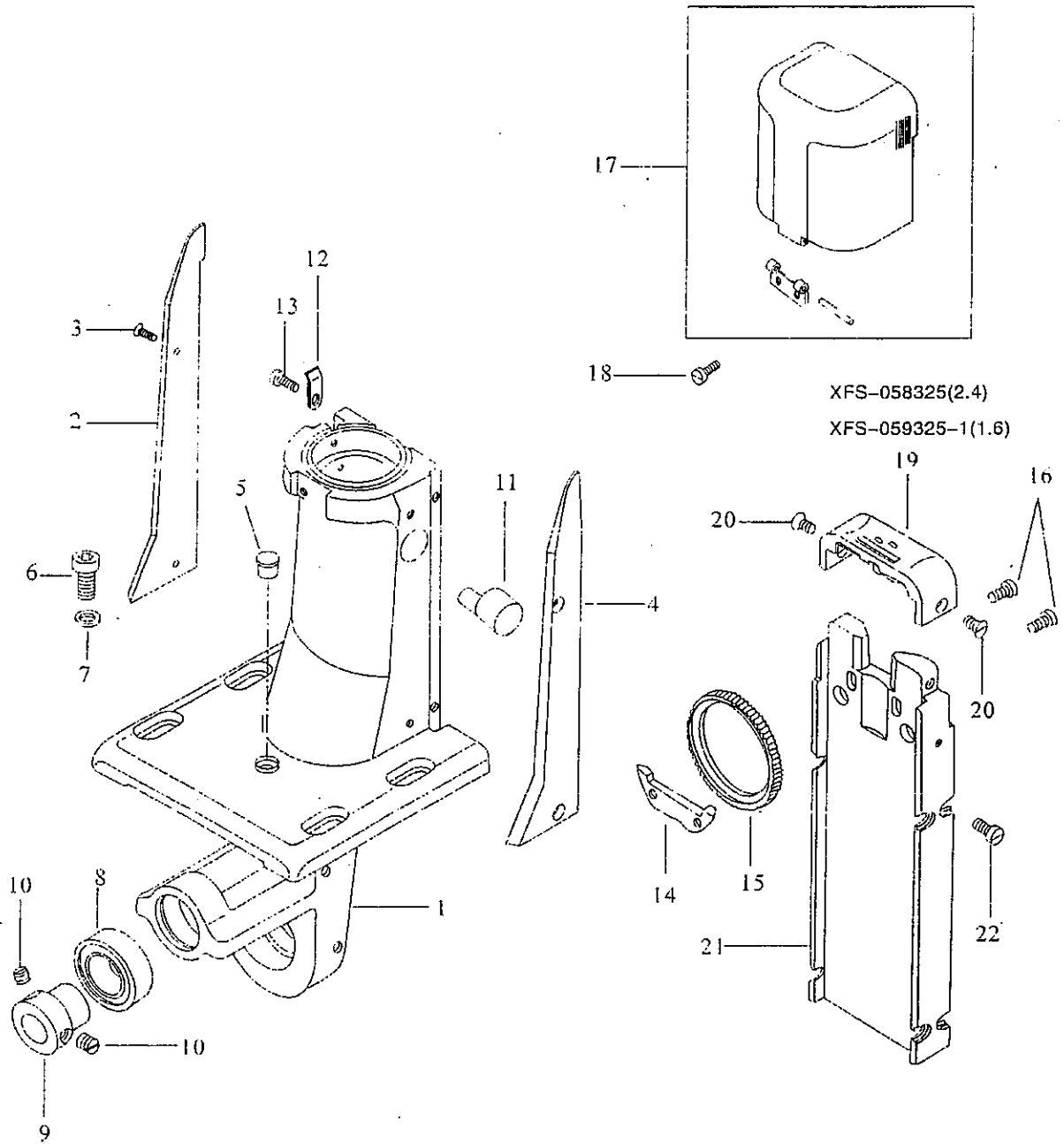

## 左邊座轉動機構

Ref.No	Part No.	Name Of Part	Amt. req.		Remark
			8810	8820	
1-9	XFS-100529	Screw	0	3	
1-10	XFS-119376	Hook	0	1	
?	XFS-010079	Bobbin	0	1	
2-1	XFS-0100158	Bobbin Case	0	1	
3	XFS-100205	Screw	0	2	
4	XFS-119716	Bobbin Case Assy	0	1	
5	XFS-119129	Rotating Hook Opener	0	1	
6	XFS-108093	Screw	0	2	
7	XFS-119494	Driving Wheel	0	1	
8	XFS-700689	Screw	0	8	
9	XFS-694ZZ	Ball Bearing	0	1	(9)
9-1	XFS-119106-1	Driver	0	1	
10	XFS-119106	Driver	0	1	
11	XFS-108177	Screw	0	1	
12	XFS-119105	Washer	0	1	
13	XFS-119128	Oil Felt	0	1	
14	XFS-119127	Rotating Hook Opener Bracket	0	1	
15	XFS-119525-1	Hook Driver	0	1	
16	XFS-119525	Hook Shaft	0	1	
17	XFS-215031	Needle Bearing	0	1	
18	XFS-215028	Needle Bearing	0	1	
19	XFS-119108	Feed Wheel Shaft	0	1	
20	XFS-125010	Washer	0	1	
21	XFS-119104	Pull-Off Shaft	0	1	
21-1	XFS-119108-1	Washer	0	1	
22	XFS-141710	Needle Bearing	0	2	
23	XFS-119979	Bushing	0	1	
24	XFS-664390	Retaining Ring	0	1	
25	XFS-175138	Bushing	0	1	
26	XFS-119107	Bushing	0	1	
27	XFS-341901	Screw	0	2	
28	XFS-119950	Screw	0	1	
29	XFS-119947	Washer(0.2)	0	1	
29-1	XFS-119957	Washer(0.1)	0	2	
29-2	XFS-119958	Washer(0.15)	0	1	
29-3	XFS-119959	Washer(0.5)	0	1	
29-4	XFS-119960	Washer(2.0)	0	1	
30	XFS-119109-1	Bevel Gear (Large)	0	1	
31	XFS-119109-2	Bevel Gear (Small)	0	1	
32	XFS-119108	Bevel Gear Assy	0	1	(8,30,31)
33	XFS-125010	Washer(0.5)	0	2	
33-1	XFS-122718	Washer(0.1)	0	1	
33-2	XFS-125008	Washer(0.15)	0	1	
33-3	XFS-125009	Washer(0.2)	0	1	
34	XFS-119133-1	Bevel Gear (Small)	0	1	
35	XFS-119133-2	Bevel Gear(Large)	0	1	
36	XFS-341901-1	Screw	0	2	
37	XFS-119133	Gear Set	0	1	(8,34-36)
38	XFS-123778	Collar	0	1	

左邊座傳動機構

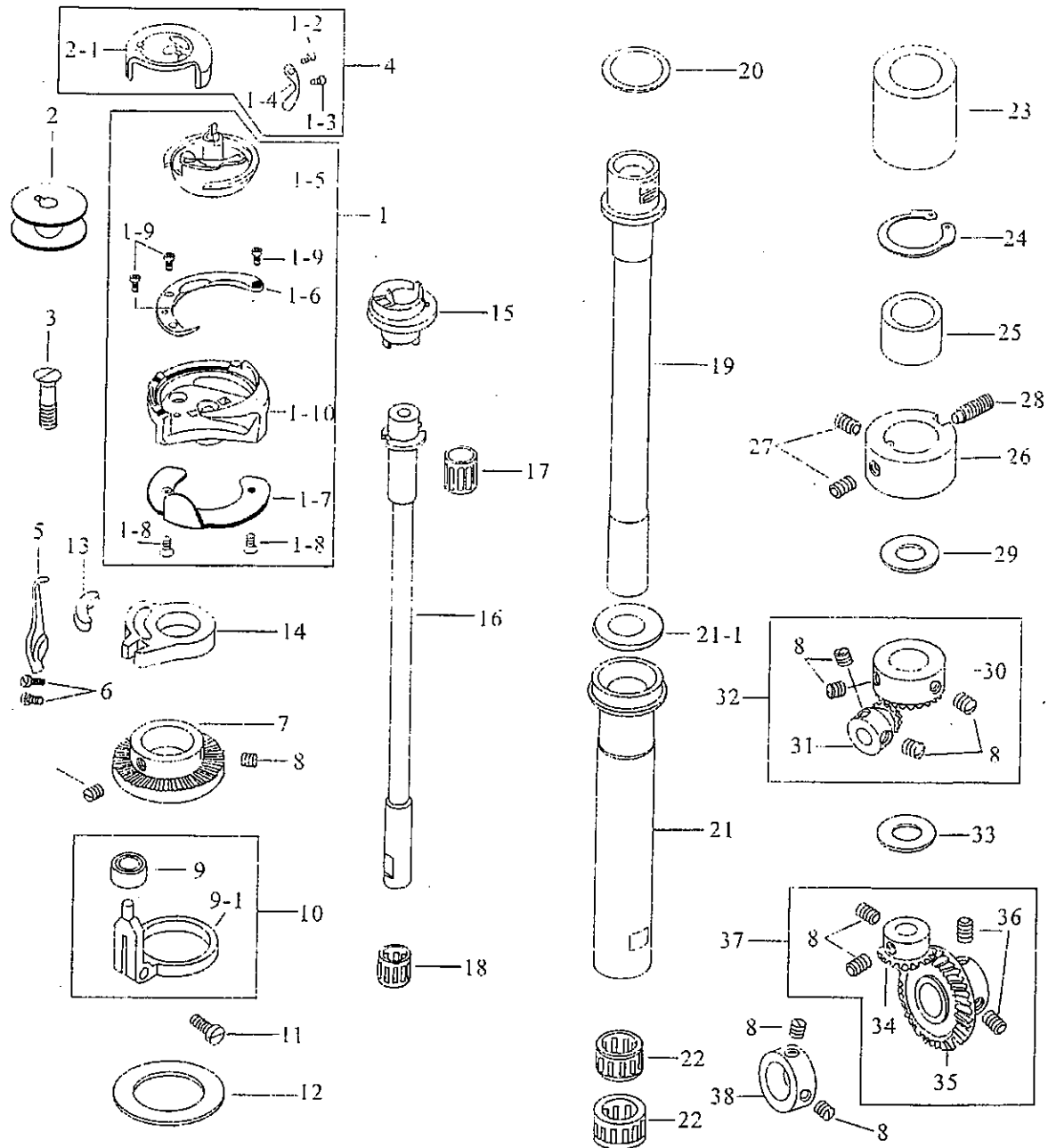

Ref.No	Part No.	Name Of Part	Amt. req.		Remarks
			8810	8820	
1	XFS-119716A	Hook Assy	0	1	1-1~10
1-2	XFS-000390	Screw	0		
1-3	XFS-000928	Screw	0	1	
1-4	XFS-010166	Spring	0	1	
1-5	XFS-119487	B/C Base	0	1	
1-6	XFS-175136	Hook Gib	0	1	
1-7	XFS-119377	Noodle Guare Washer	0	1	
1-8	XFS-000219	Screw	0	2	

## 右邊座傳動機構

Ref.No	Part No.	Name Of Part	Amt. req.		Remarks
			8810	8820	
1	XFS-119695	Cover Plate 邊蓋板	0	1	
2	XFS-250084	Screw 螺絲	4	4	
3	XFS-175267	Cover Plate 邊蓋板	1	0	
4	XFS-700336	Screw 螺絲	2	0	
5	XFS-175318	Stud 調整梢	1	1	
6	XFS-330217	Screw 螺絲	1	1	
7	XFS-175324	Side Bracket(Right) 單針邊座	1	0	
7-1	XFS-119168	Side Bracket (Right) 單針邊座	0	1	
8	XFS-119436	Post Cap Assy 斧蓋	1	0	
9	XFS-108093	Screw 螺絲	2	0	
10	XFS-119143	Spring Plate 彈簧板	1	1	
11	XFS-108093	Screw 螺絲	1	1	
12	XFS-135292	Screw 螺絲	4	4	
13	XFS-305174	Washetr 碟形華司	4	4	
14	XFS-016120	Ball Bearing 滾珠軸承	1	1	
15	XFS-119121	Collar 止軸套管	1	1	
16	XFS-700689	Screw 螺絲	2	2	
17	XFS-175234	Cover Plate 邊蓋板	1	0	
18	XFS-119499	Cover Plate 邊蓋板	0	1	

右邊座傳動機構

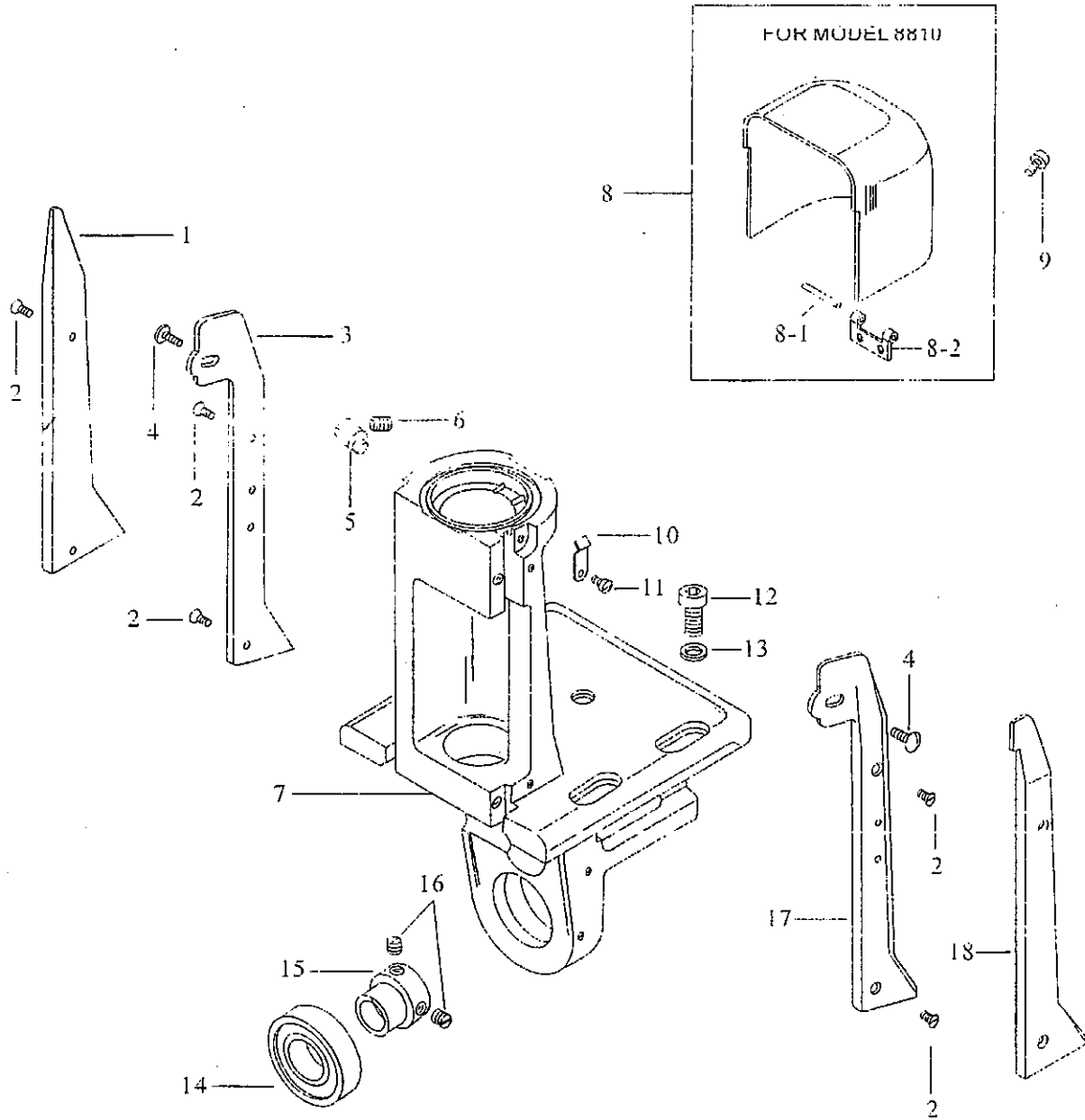

單向齒輪傳動機構

Ref.No	Part No.	Name Of Part	Amt. req.		Remarks
			8810	8820	
1	XFS-119507	Link 萬向軸承拉杆	2	1	(4,5) (4,5)
2	XFS-119087	Oil Felt 油棉	2	1	
3	XFS-174176	Screw 螺絲	4	2	
4	XFS-061014	Needle Bearing 針狀軸承	2	2	
5	XFS-119115-1	Free-Wheeling Seat 單向培林座	2	2	
6	XFS-119112	Free-Wheeling(Left) 單向培林座組(左)	1	1	
7	XFS-119115	Free-Wheeling(Right) 單向培林座組(右)	1	1	
8	XFS-012555	Ball Bearing 滾珠軸承	2	2	
9	XFS-664350	Retaining Ring C型扣環	2	2	
10	XFS-173174	Screw 螺絲	1	1	
11	XFS-119111	Shaft 培林軸	1	1	
12	XFS-119216	Housing Front Section 護片	1	1	
13	XFS-108174	Screw 螺絲	4	4	
14	XFS-119115-3	Screw 螺絲	0	1	



單向齒輪傳動機構

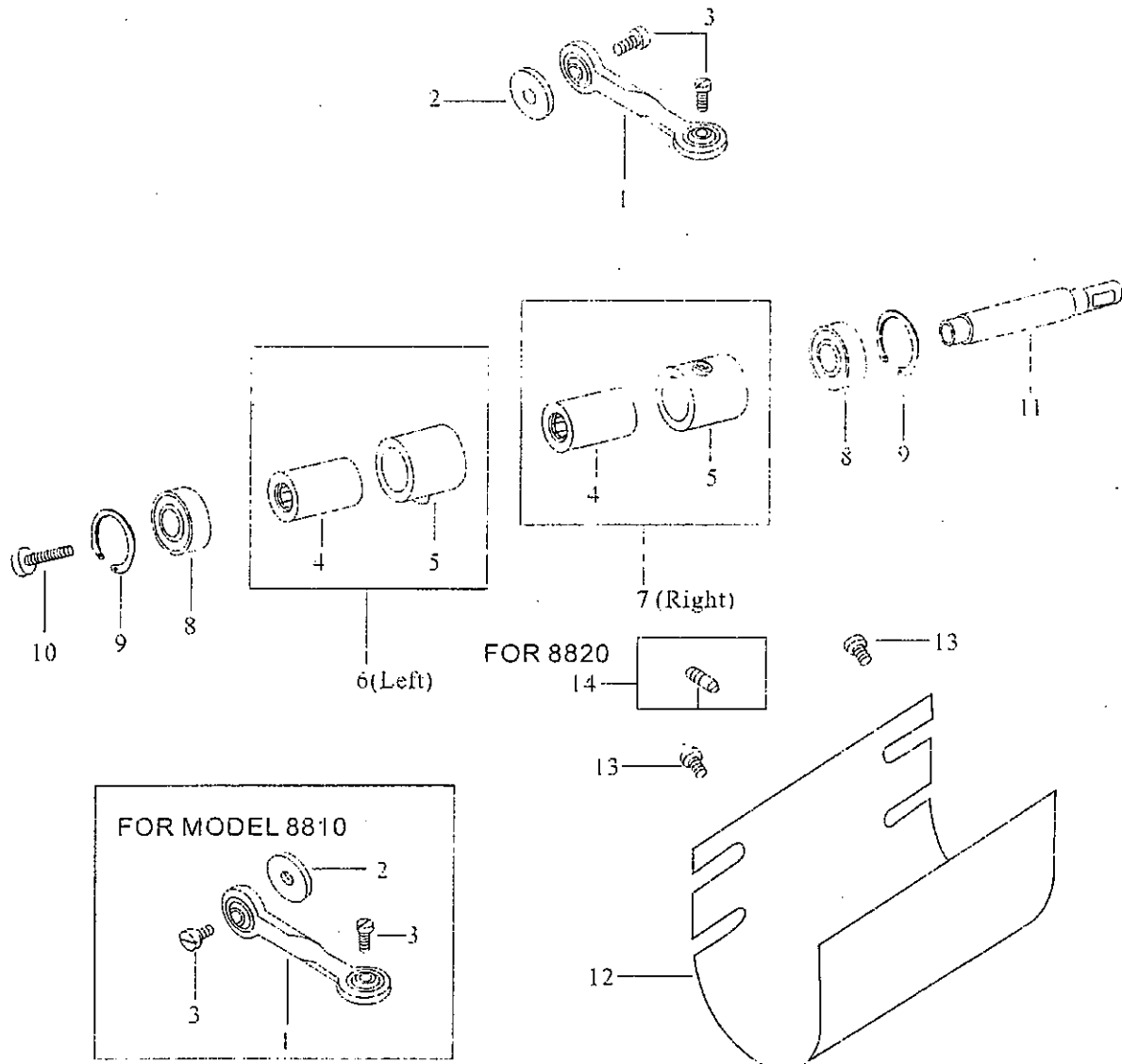

右邊座傳動機構

Ref.No	Part No.	Name Of Part	Amt. req.		Remarks
			8810	8820	
1	XFS-119716A	Hook Assy 卡馬組	1	1	(1-1-8)
1-2	XFS-000390	Screw 螺絲	1	1	
1-3	XFS-000928	Screw 螺絲	1	1	
1-4	XFS-010166	Spring 彈簧	1	1	
1-5	XFS-119487	B/C Base 梭仔座	1	1	
1-6	XFS-175136	Hook Gib 內梭頭舌	1	1	
1-7	XFS-119377	Needle Guard Washer 護針片	1	1	
1-8	XFS-000219	Screw 螺絲	2	2	
1-9	XFS-100529	Screw 螺絲	3	6	
1-10	XFS-119376	Hook 梭頭	1	1	
2	XFS-010079	Bobbin 梭仔	1	1	(9)
2-1	XFS-010158	Bobbin Case 梭殼	1	2	
3	XFS-100205	Screw 螺絲	1	2	
4	XFS-119716	Bobbin Case Assy 梭殼蓋	1	1	
5	XFS-119128	Oil Felt 油綫	1	1	
6	XFS-119127	Rotating Hook Opener Bracket 半角座	1	1	
7	XFS-119129	Rotating Hook Opener 半角	1	1	
8	XFS-108093	Screw 螺絲	2	2	
9	XFS-694ZZ	Ball Bearing 滾珠軸承	1	1	
9-1	XFS-119106-1	Driver 固定座	1	1	
10	XFS-119106	Driver 半角固定座	1	1	
11	XFS-108177	Screw 螺絲	1	1	
12	XFS-119105	Washer 華司	1	1	
13	XFS-119525-1	Hook Driver 梭軸頭	1	1	
14	XFS-119525	Hook Shaft 梭軸	1	1	
15	XFS-215031	Needle Bearing 針狀軸承	1	1	
16	XFS-215028	Needle Bearing 針狀軸承	1	1	
17	XFS-119524	Feed Wheel Shaft 梭軸中套管	1	1	
18	XFS-119979	Bushing 梭軸套管	1	1	
19	XFS-664390	Retaining Ring C型扣環	1	1	
20	XFS-175138	Bushing 偏心軸	1	1	
21	XFS-119107	Bushing 梭軸套管	1	1	
22	XFS-119950	Screw 螺絲	1	1	
23	XFS-341901	Screw 螺絲	4	4	
24	XFS-131088	Collar 定環	1	1	
25	XFS-125010	Washer(0.5) 華司	2	2	
25-1	XFS-122718	Washer(0.1) 華司	1	1	
25-2	XFS-125008	Washer(0.15) 華司	1	1	
25-3	XFS-125009	Washer(0.2) 華司	1	1	
26	XFS-119133-1	Bevel Gear(small) 齒輪(小)	1	1	(26-29)
27	XFS-119133-2	Bevel Gear(large) 齒輪(大)	1	1	
28	XFS-700689	Screw 螺絲	4	4	
29	XFS-341901-1	Screw 螺絲	2	2	
30	XFS-119133	Gear Set 梭軸齒輪組	1	1	
31	XFS-123778	Collar 定環	1	1	

右邊座傳動機構

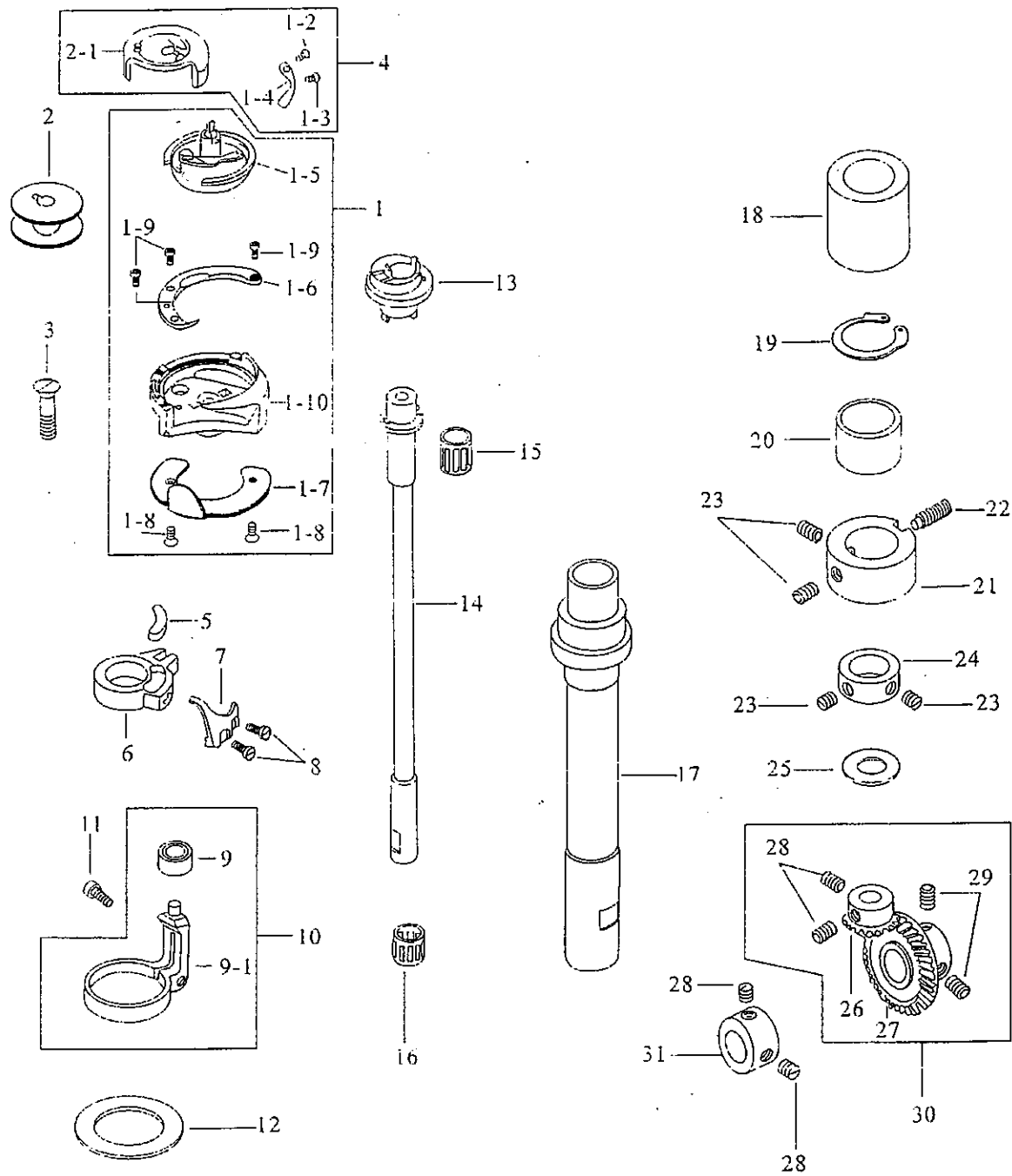

特殊配件

Ref.No	Part No.	Name Of Part	Amt. req.		Remark
			8810	8820	
1	XFS-123456	Accessory Bag 零件袋	1	1	
2	XFS-029836	Vinyl Cover 車頭蓋	1	1	
3	XFS-800110	Spanner 扳手	1	1	
4	XFS-129915	Screw Driver(Small) 螺絲起子(小)	1	1	
5	XFS-029946	Screw Driver(Middle) 螺絲起子(中)	1	1	
6	XFS-029007	Screw Driver (Large) 螺絲起子(大)	1	1	
7	XFS-134356	Needle 針	10	10	
8	XFS-029394	Oiler 油壺	1	1	
9	XFS-119089-1	Stitching Length Indicator 指示針	1	1	
10	XFS-100355	Screw 螺絲	1	1	
11	XFS-032808	Head Cushion 腳墊(小)	2	2	
12	XFS-010079	Bobbin 梭仔子	4	4	
13	XFS-259431	Bobbin Winder 卷線器	1	1	
14	XFS-119026	Spool Pin 邊線器	1	1	
15	XFS-FPL2	Thread Stand(2-Pole) 單針線架	1	0	
16	XFS-FPL3	Thread Stand(3-Pole) 雙針線架	0	1	

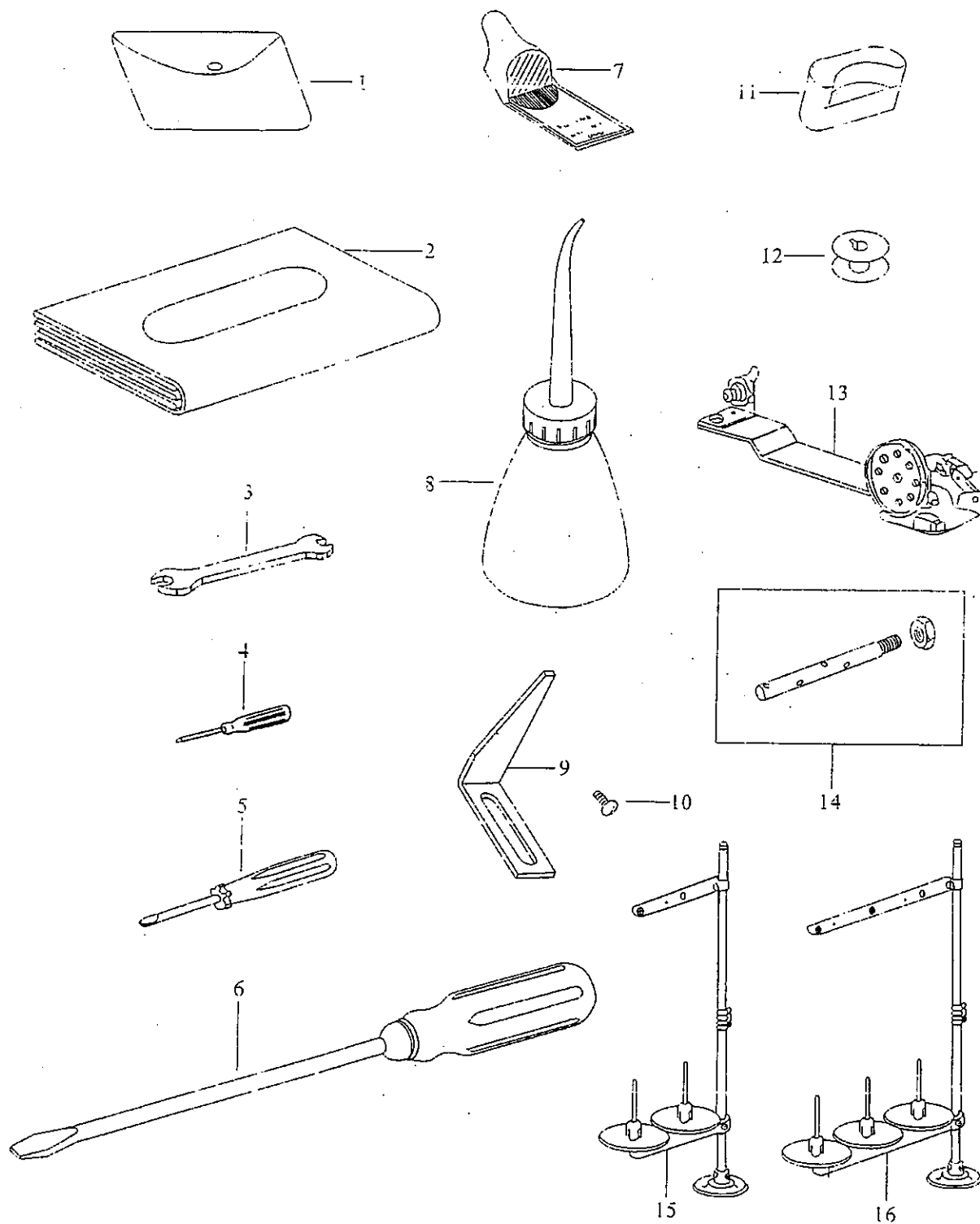

## 附件

Ref.No.	Part No.	Name Of Part		Amt. req.		Remarks
				8810	8820	
1	XFS-171543	Spring	彈簧	1	1	(2~4)
2	XFS-171542	Knee Lever Coupling	腳押連杆頭	1	1	
3	XFS-171413	Knee Lever Rod	腳押軸	1	1	
4	XFS-171412	Knee Lever Assy	腳弓軸	1	1	
5	XFS-171411	Knee Lever Rod Assy	腳弓押組	1	1	
6	XFS-029934	Hinge Connection Seat	后鈕腳墊(大)	2	2	
7	XFS-030341	Pin	平行梢	2	2	
8	XFS-029450	Hinge Pin	后鈕鈎	2	2	
9	XFS-118636	Oil Pan	油槽	1	1	
10	XFS-460157	Screw	螺絲	6	6	
11	XFS-032717	Head Rest Wood	枕木	1	1	
12	XFS-032717-1	Housing Support Stud	固定梢	1	1	
13	XFS-119078	Belt Cover Set(Large)	皮帶蓋(大)	1	1	
13-1	XFS-119089-2	Screw	螺絲	2	2	
14	XFS-119088	Belt Cover Set(Small)	皮帶蓋(小)	1	1	
14-1	XFS-119078-1	Screw	螺絲	2	2	

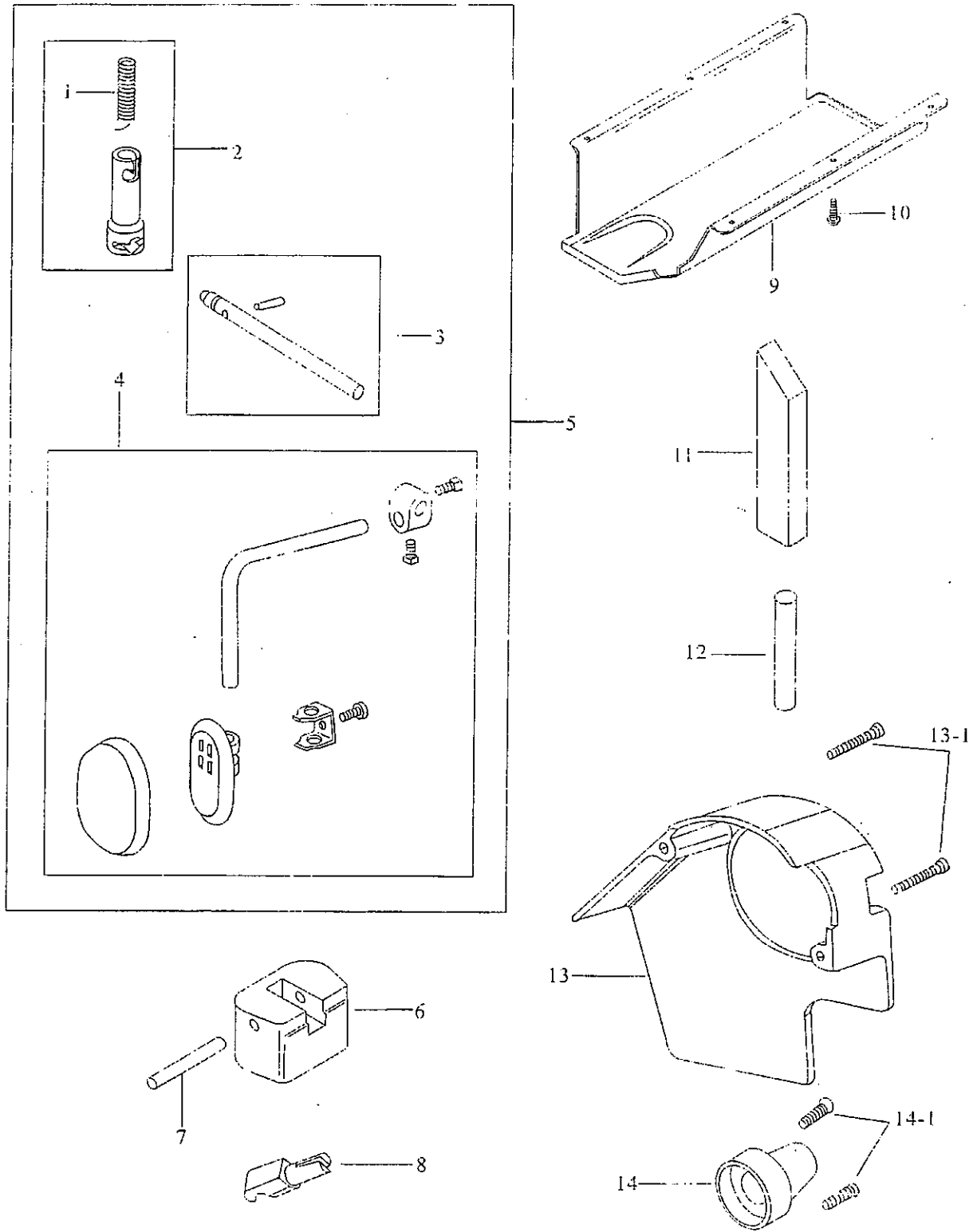



8820-1



8820-2

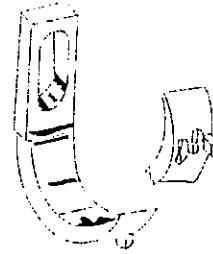

8820-3

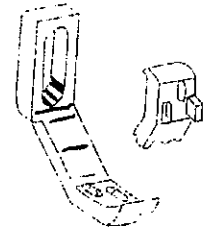

8820-4

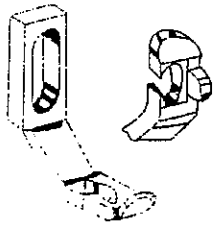

8820-5

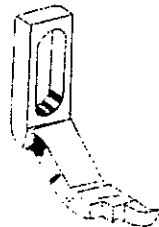

8820-6

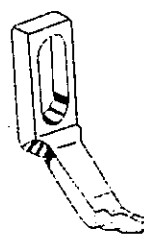

8820-7

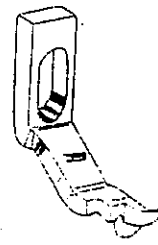

8820-8



8820-9

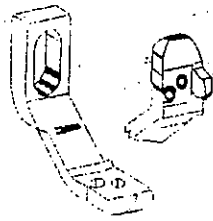

8820-10

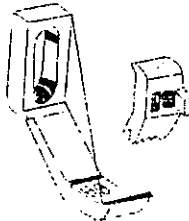

8820-11

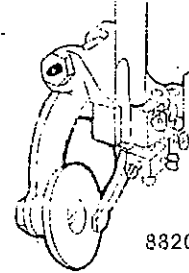

8820-K2

8820-12  
8820 Garge

